

Perforated Face Rotating Core Supply Diffuser Steel, Round Neck, Surface Mount

Imperial [IP] Dimensions
Metric (SI) in Parentheses

CARNES COMPANY 448 S. Main St., P. O. Box 930040, Verona, WI 53593-0040 Phone: (608)845-6411 Fax: (608)845-6504 www.carnes.com

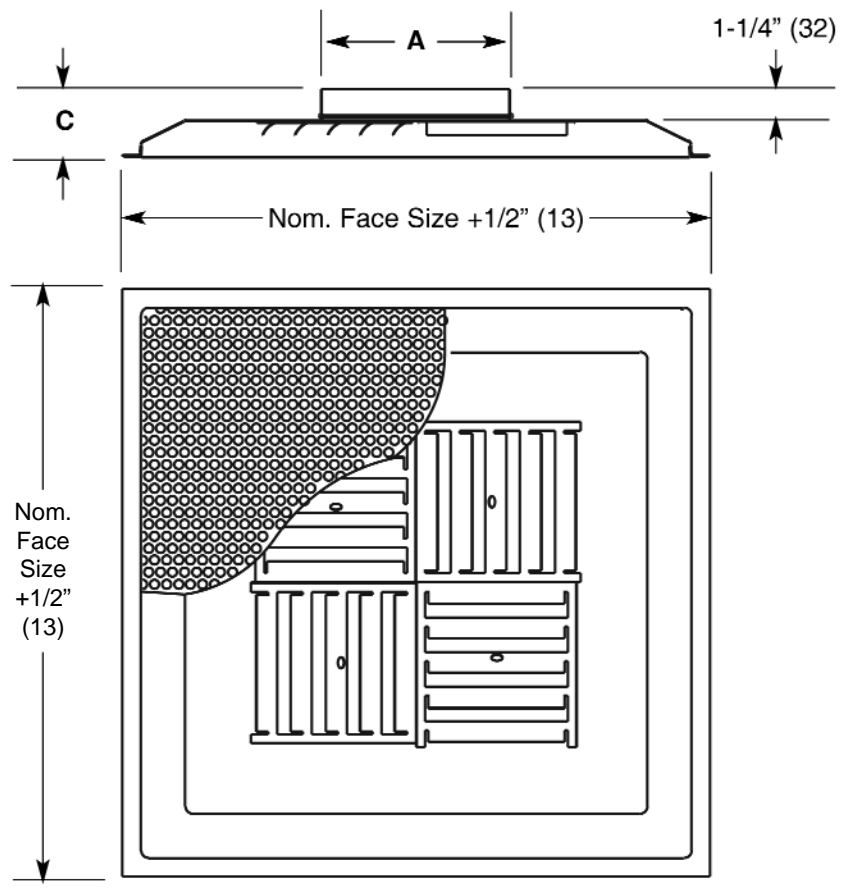
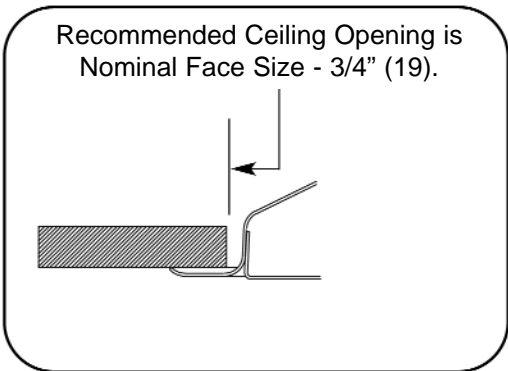
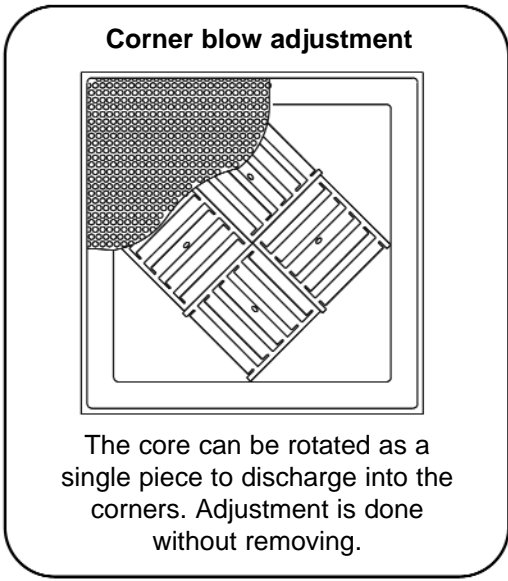
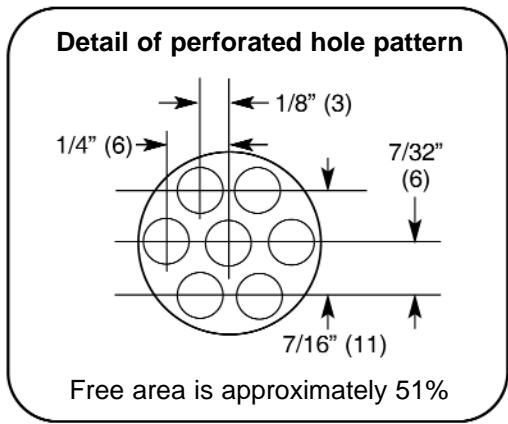

- NOTES:**
1. Standard construction on SP model is steel. Aluminum face plate is available on request (Options A & B).
 2. Standard construction on SL model is aluminum ceiling plate and face plate.
 3. Standard finish is electrocoat acrylic baked enamel.
 4. Standard color is #11 Bright White. Other colors are available on request.
 5. Round neck is undersized by 1/8" (3) to fit inside the duct.
 6. Recommended balancing damper is model KXMB damper.
 7. Metric dimensions are given in millimeters.

Model Number	Nom. Face Size	Round Neck Nom. Size (A)	Unit Height (C)
SPXB 112 06	12" x 12"	6" (152)	2-1/2"
SPXB 112 08	(305 X 305)	8" (203)	(64)
SPXB 222 06		6" (152)	
SPXB 222 08		8" (203)	
SPXB 222 10	24" X 24"	10" (254)	2-3/4"
SPXB 222 12	(610 X 610)	12" (305)	(70)
SPXB 222 14		14" (356)	
SPXB 222 16		16" (406)	