

Imperial [IP] Dimensions
Metric (SI) in Parentheses

CARNES COMPANY 448 S. Main St., P. O. Box 930040, Verona, WI 53593-0040 Phone: (608)845-6411 Fax: (608)845-6504 www.carnes.com

Grille Model
RSSB (Steel)

Register Model
RTSB (Steel)

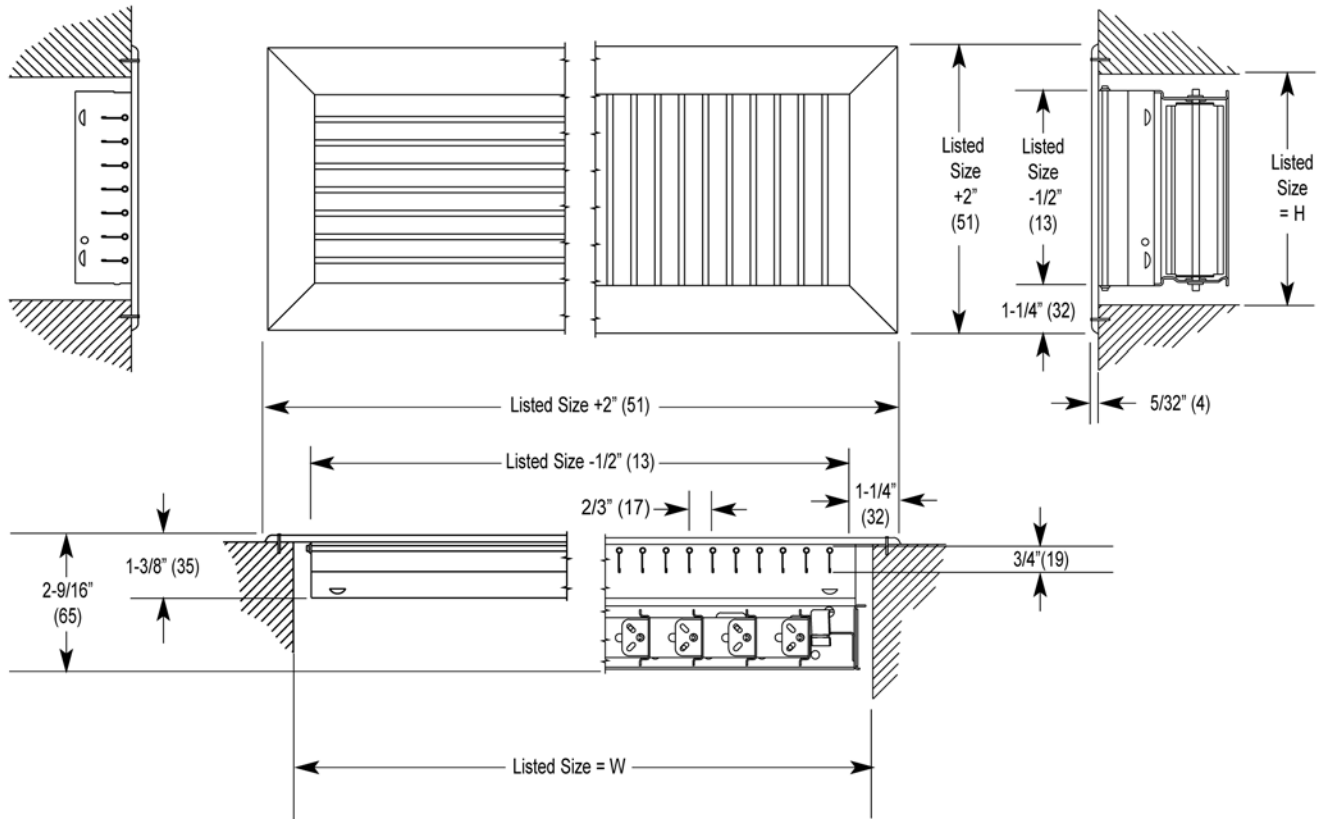

Notes:

1. Standard screws are #6 x 1-1/4" (32) phillips trusshead screws.
2. Polyurethane foam gasket around edge of frame is standard.
3. The standard finish is electrocoat acrylic baked enamel. Other finishes available on request.
4. The standard color is #11 Bright White. Other colors are available on request.
5. Blades can be aligned either horizontally or vertically, and are individually adjustable.
6. Center mullion is used for blade lengths exceeding 24" (610) nominal size in either dimension on steel models RSSB and RTSB.
7. Standard sizing is in even inch increments in both dimensions. Odd inch and fractional sizing [in 1/8" (3) increments] is available on request.
8. Center mullion is used for blade lengths exceeding 18" (457) nominal size on aluminum Models RASB, RWSB and RNSB.
9. This product is covered by U.S. Patent #5,771,647.
10. Steel damper is Model RXEA opposed blade damper.
11. The standard operator on the damper takes a medium size flat-blade screwdriver.
12. Maximum size shown is the maximum single panel size. Panels can be joined for larger sizes.
13. Metric dimensions are given in millimeters.

Model	Construction	Damper	Blade Alignment	Minimum W x H	Maximum W x H
RSSBH	Steel	None	Horizontal	4" x 4" (102 x 102)	36" x 36" (914 x 914)
RSSBV	Steel	None	Vertical		
RTSBH	Steel	Yes	Horizontal		
RTSBV	Steel	Yes	Vertical		