

Application:

Single Deflection Supply R&G provide a discharge directly away from the wall or ceiling and either vertical or horizontal adjustment of the air stream.

Standard Features:

- Steel construction is durable and inexpensive.
- Blades are 3/4" deep, on 2/3" centers.
- Individually adjustable teardrop blades.
- Blades can be aligned horizontally or vertically.
- Mounts in most wall or ceiling styles.
- Foam gasket around edge of frame is standard.
- Register uses model RXEA opposed blade damper (p. A437).
- Minimum panel size is 4" x 4".
- Maximum panel size is 36" x 36". Panels can be joined for larger sizes (p. A311).
- Standard finish is electrocoat acrylic baked enamel.
- Standard color is #11 bright white.

Optional Features:

- UL listed fusible link (p. A343).
- Tamper-proof screws (p. A342).
- Concealed hangers (p. A343).
- Pull cord and lever damper operators (p. A343).
- Debris screen (p. A343).

Quick Select Chart

This shows grilles with: • A maximum NC of 35.
• A minimum duct velocity of 300 FPM.

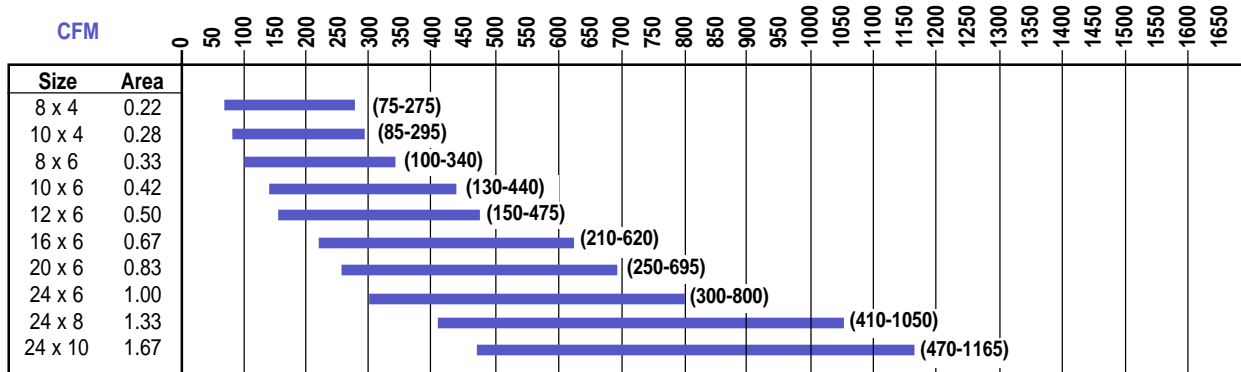

Model Numbering System

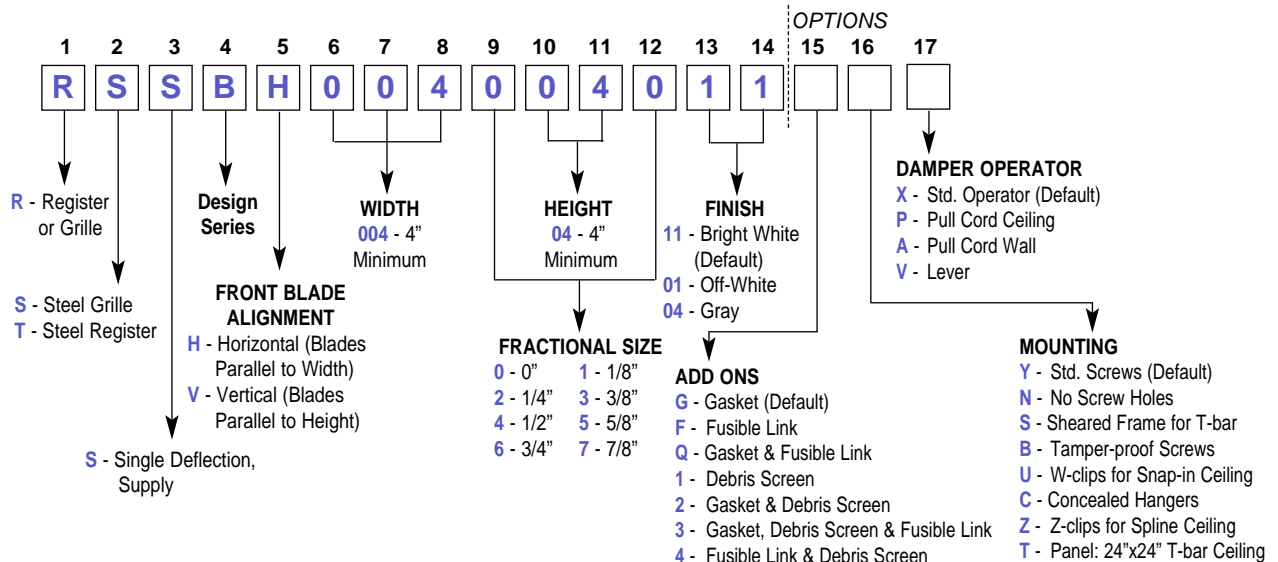

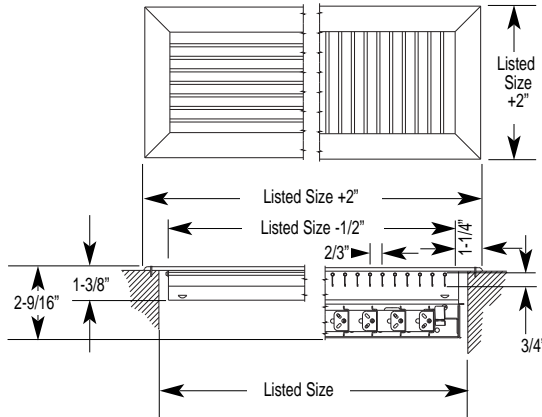

Application:

Single Deflection Supply R&G provide a discharge directly away from the wall or ceiling and either vertical or horizontal adjustment of the air stream.

Standard Features:

- Stainless steel (type 304) construction is highly corrosion resistant.
- Blades are 3/4" deep, on 2/3" centers.
- Individually adjustable teardrop blades.
- Blades can be aligned horizontally or vertically.
- Mounts in most wall or ceiling styles.
- Foam gasket around edge of frame is standard.
- Register RMSB uses opposed blade damper RXEA (p. A437).
- Register RKSb uses opposed blade damper RXTA (p. A437).
- Minimum panel size is 4" x 4".
- Maximum panel size is 36" x 36". Panels can be joined for larger sizes (p. A311).
- Standard finish is #22 satin polish with one coat of clear lacquer.

Optional Features:

- Tamper-proof screws (p. A342).
- Concealed hangers (p. A343).
- Pull cord and lever damper operators (p. A343).
- Debris screen (p. A343).

Quick Select Chart

This shows grilles with:

- A maximum NC of 35.
- A minimum duct velocity of 300 FPM.

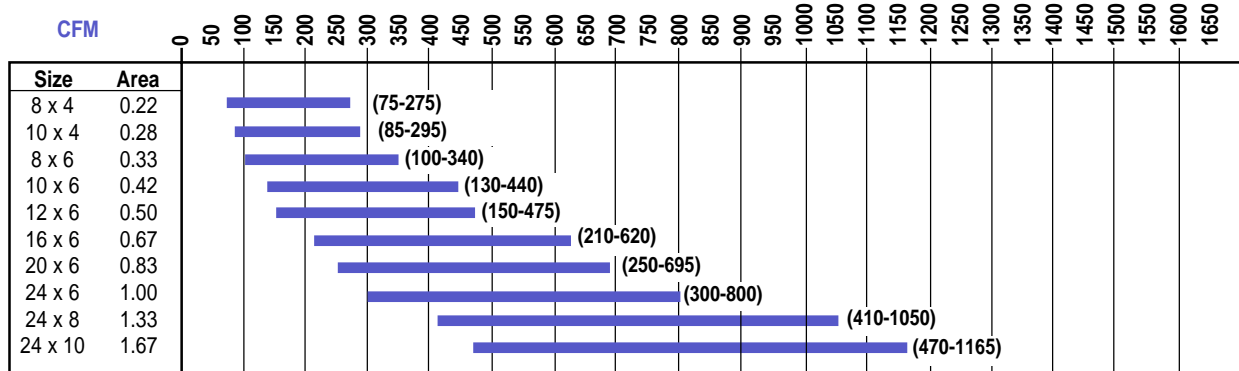

Model Numbering System

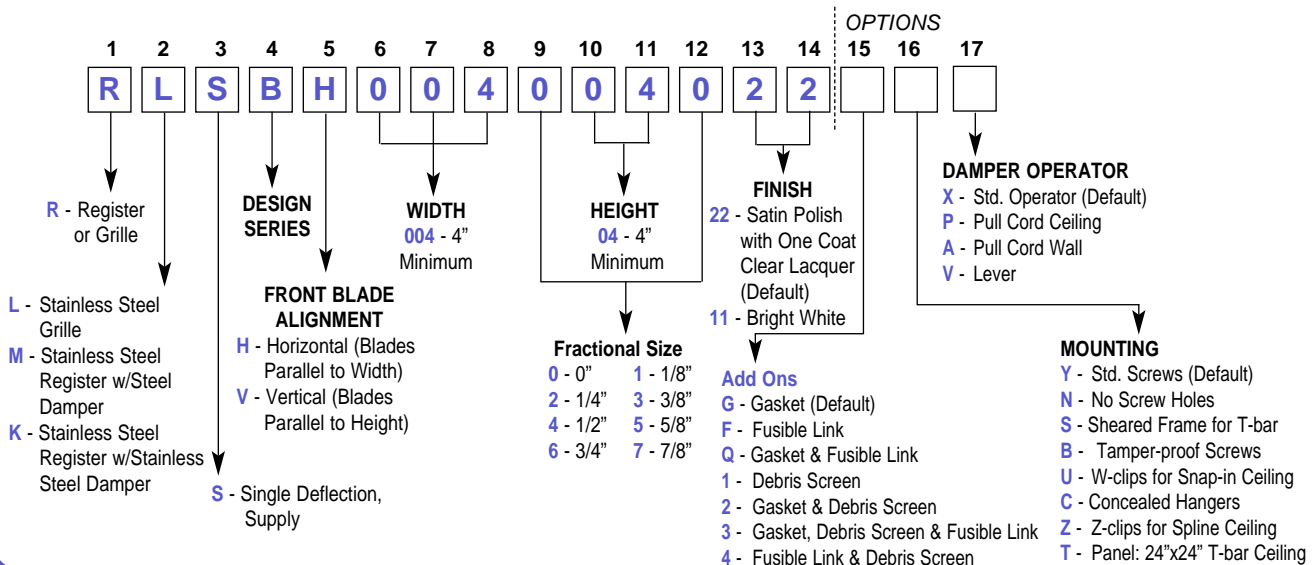

- Steel (RSSB, RTSB) • Stainless Steel (RLSB, RMSB, RKSB)

Correction Factors for Grille Performance

• **Total Pressure (Pt)**

Use table data unchanged.

• **Throw**

Use table data unchanged for 0° setting. Multiply the table data by the following factor for different blade angle settings.

Blade Angle Setting	22-1/2°	45°
Factor	0.89	0.60

• **Sound Level**

Use table data unchanged for 0° setting. Add the following to arrive at NC values for different blade angle settings.

Duct Velocity (fpm)	300	400	500	600	700	800	900	1000	1200
45° Blade Setting	6	6	6	6	5	5	5	5	5

Correction Factors for Register Performance

• **Total Pressure (Pt)**

Use table data unchanged for 0° setting. Multiply the table data for Total Pressure by the following factor for different blade angle settings.

Blade Angle Setting	0°	22-1/2°	45°
Factor	1.80	1.65	1.10

• **Throw**

Use table data unchanged for 0° setting. Multiply the table data by the following factor for different blade angle settings.

Blade Angle Setting	22-1/2°	45°
Factor	0.89	0.60

• **Sound Level**

Use table data unchanged for 0° setting. Add the following to arrive at NC values for different blade angle settings.

Duct Velocity (fpm)	300	400	500	600	700	800	900	1000	1200
45° Blade Setting	8	8	8	8	8	7	7	7	7

Nominal Size	Duct Velocity		300	400	500	600	700	800	900	1000	1200	
			Duct Total	0.010	0.014	0.023	0.034	0.047	0.063	0.081	0.100	0.150
			Area Press. 22-1/2° (ft ²) (Pt)	0.012	0.021	0.034	0.051	0.071	0.096	0.125	0.155	0.225
6x6	0.25	Flow (CFM)	75	100	125	150	175	200	225	250	300	
		Throw	8	10	13	16	18	21	24	26	30	
		Sound (NC)	<20	<20	<20	<20	<20	<20	<20	22	27	
8x6 12x4	0.33	Flow (CFM)	100	135	170	200	235	270	305	335	405	
		Throw	9	12	15	18	21	27	27	30	35	
		Sound (NC)	<20	<20	<20	<20	<20	<20	22	25	31	
10x6	0.42	Flow (CFM)	130	180	220	260	310	350	400	440	530	
		Throw	9	13	17	20	24	28	30	33	40	
		Sound (NC)	<20	<20	<20	<20	<20	22	25	28	34	
12x6	0.50	Flow (CFM)	150	200	250	300	350	400	450	500	595	
		Throw	10	14	18	21	25	29	32	35	43	
		Sound (NC)	<20	<20	<20	<20	<20	23	26	29	35	
14x6	0.58	Flow (CFM)	175	230	280	340	390	450	510	560	680	
		Throw	11	15	19	22	27	31	34	37	45	
		Sound (NC)	<20	<20	<20	<20	20	24	28	31	36	
12x8 16x6	0.67	Flow (CFM)	210	280	350	400	480	550	620	690	830	
		Throw	13	17	21	24	29	33	37	41	50	
		Sound (NC)	<20	<20	<20	<20	22	26	30	33	38	

Notes on Performance Data:

- Throw data is based on wall mounting height of 8-10 feet.
- Throw values are given in feet to a terminal velocity of 50 fpm.
- Testing was conducted under 20°ΔT cooling conditions.
- NC values are based on a room absorption of 10db re 10⁻¹² watts.
- Actual performance in the field may vary.

Sq. & Rect. Registers & Grilles

- Steel (RSSB, RTSB)
- Stainless Steel (RLSB, RMSB, RKSB)

Nominal Size	Duct Velocity	Area Press. 22-1/2° (ft²) (Pt)	0°	300	400	500	600	700	800	900	1000	1200
				0.010	0.014	0.023	0.034	0.047	0.063	0.081	0.100	0.150
				0.012	0.021	0.034	0.051	0.071	0.096	0.125	0.155	0.225
18x6	0.75	Flow (CFM)	Throw	230	310	380	460	530	610	690	760	920
				14	18	22	25	30	35	39	43	53
				<20	<20	<20	<20	23	27	31	34	39
12x10 30x4 20x6	0.83	Flow (CFM)	Throw	250	330	420	500	580	670	750	830	1000
				14	18	23	26	31	36	41	45	54
				<20	<20	<20	20	24	28	31	34	40
12x12	1.00	Flow (CFM)	Throw	300	400	500	600	700	800	900	1000	1200
				15	20	25	29	34	40	45	49	59
				<20	<20	<20	22	26	30	33	36	42
14x14	1.36	Flow (CFM)	Throw	410	540	680	820	950	1090	1220	1360	1630
				17	22	29	34	40	46	51	56	69
				<20	<20	<20	26	29	33	36	39	45
18x12 36x6	1.50	Flow (CFM)	Throw	470	620	780	930	1090	1240	1400	1560	1870
				18	24	31	37	43	48	54	60	73
				<20	<20	20	26	32	34	37	41	46
16x16	1.77	Flow (CFM)	Throw	530	710	890	1070	1250	1420	1600	1780	2100
				20	26	33	40	46	51	58	65	77
				<20	<20	21	27	31	35	39	44	47
18x16 24x12	2.00	Flow (CFM)	Throw	600	800	1000	1200	1400	1600	1800	2000	2400
				21	27	35	42	49	54	61	68	81
				<20	<20	22	28	32	36	40	44	48
18x18	2.25	Flow (CFM)	Throw	680	900	1120	1350	1580	1800	2000	2200	2700
				22	29	37	44	52	58	65	71	87
				<20	<20	24	29	33	37	41	45	49
20x20 22x18 40x10	2.78	Flow (CFM)	Throw	830	1110	1390	1670	1950	2200	2500	2800	3330
				24	32	41	49	57	65	73	82	96
				<20	<20	25	31	35	39	43	46	51
36x12	3.00	Flow (CFM)	Throw	900	1200	1500	1800	2100	2400	2700	3000	3600
				25	34	43	51	59	67	75	85	105
				<20	20	26	32	36	40	44	47	53
22x22	3.36	Flow (CFM)	Throw	1010	1340	1680	2000	2400	2700	3000	3400	
				26	36	45	53	63	71	79	89	
				<20	21	27	33	37	41	45	48	
24x24 48x12	4.00	Flow (CFM)	Throw	1200	1600	2000	2400	2800	3200	3600		
				29	38	49	58	67	78	87		
				<20	22	29	34	39	43	47		
26x26 48x14 28x24	4.69	Flow (CFM)	Throw	1400	1880	2300	2800	3300	3800	4200		
				32	42	51	62	74	84	94		
				<20	24	30	36	40	44	48		
28x28	5.44	Flow (CFM)	Throw	1630	2200	2700	3300	3800	4400			
				33	45	55	69	78	91			
				<20	25	32	37	42	46			
30x30	6.25	Flow (CFM)	Throw	1880	2500	3100	3700	4400	5000			
				36	48	59	71	84	96			
				<20	26	33	38	43	47			
42x24	7.00	Flow (CFM)	Throw	2100	2800	3600	4200	5000	5700			
				38	50	65	75	90	102			
				<20	27	34	40	44	48			
48x24	8.00	Flow (CFM)	Throw	2400	3200	4000	4800	5600				
				41	54	67	82	95				
				20	28	35	41	45				
36x36	9.00	Flow (CFM)	Throw	2700	3600	4500	5400					
				44	58	73	86					
				21	30	36	42					

Notes on

Performance Data:

- Throw data is based on wall mounting height of 8-10 feet.
- Throw values are given in feet to a terminal velocity of 50 fpm.
- Testing was conducted under 20°ΔT cooling conditions.
- NC values are based on a room absorption of 10db re 10⁻¹² watts.
- Actual performance in the field may vary.

Multi-Panel Construction for the following Registers & Grilles

	Steel	Stainless Steel	Aluminum
Single Deflection	RSSB, RTSB	RLSB, RMSB, RKSB	RASM, RNSM
Double Deflection	RSDB, RTDB	RLDB, RMDB, RKDB	RADM, RNDM
0° Fixed Return	RSRB, RTRB	RLRB, RMRB, RKRB	RARM, RNRM
45° Fixed Return	RSAB, RTAB	RLAB, RMAB, RKAB	RAAM, RNAM

In-line Construction

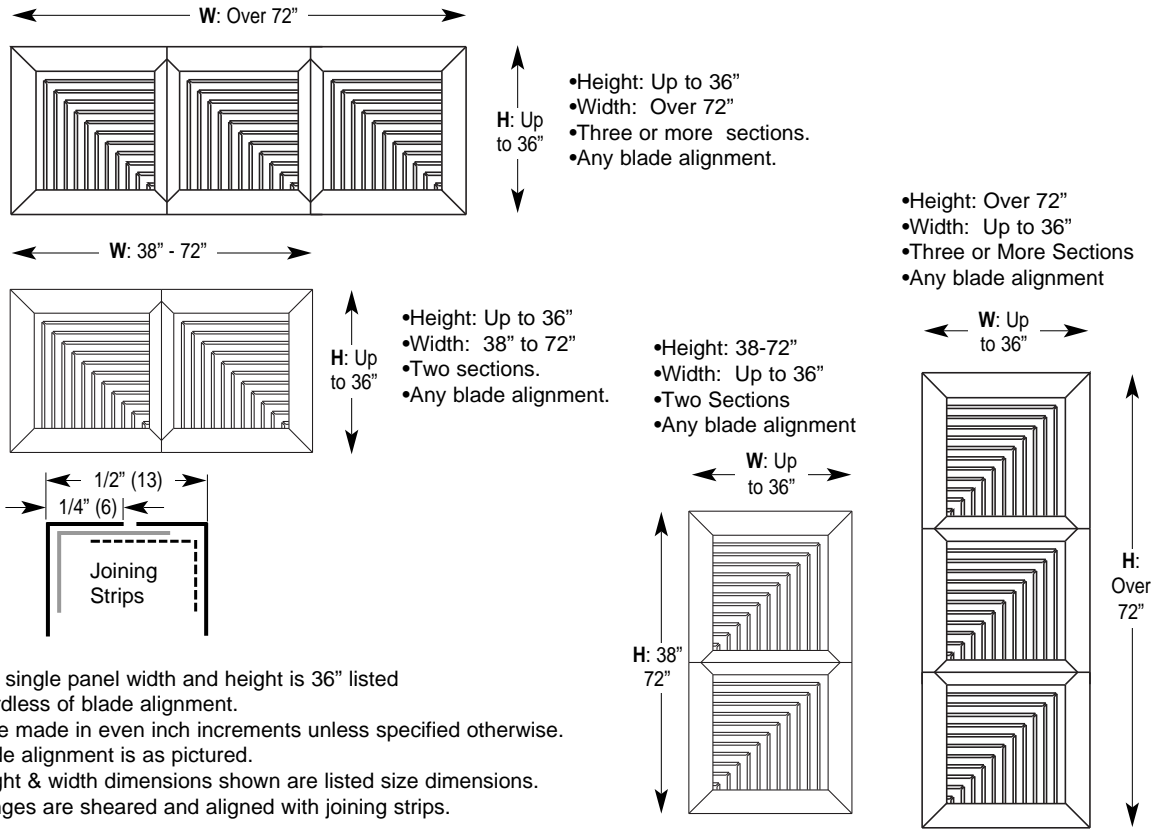

Notes:

1. Maximum single panel width and height is 36" listed size regardless of blade alignment.
2. Panels are made in even inch increments unless specified otherwise.
3. Front blade alignment is as pictured.
4. Grille height & width dimensions shown are listed size dimensions.
5. Panel flanges are sheared and aligned with joining strips.

Ganged Construction

Notes:

1. Maximum single panel width is 36" listed size.
2. Maximum single panel height is 36" listed size.
3. Panels will be made in even inch increments unless specified otherwise.
4. Front blade alignment is always parallel to center support.
5. Either the vertical or horizontal joint can be sheared down, but not both.
6. The center support can be aligned vertically or horizontally, depending on blade alignment desired. It is shown here mounted horizontally.
7. Grille height and width dimensions shown are listed size dimensions.
8. Metric dimensions are shown in millimeters.

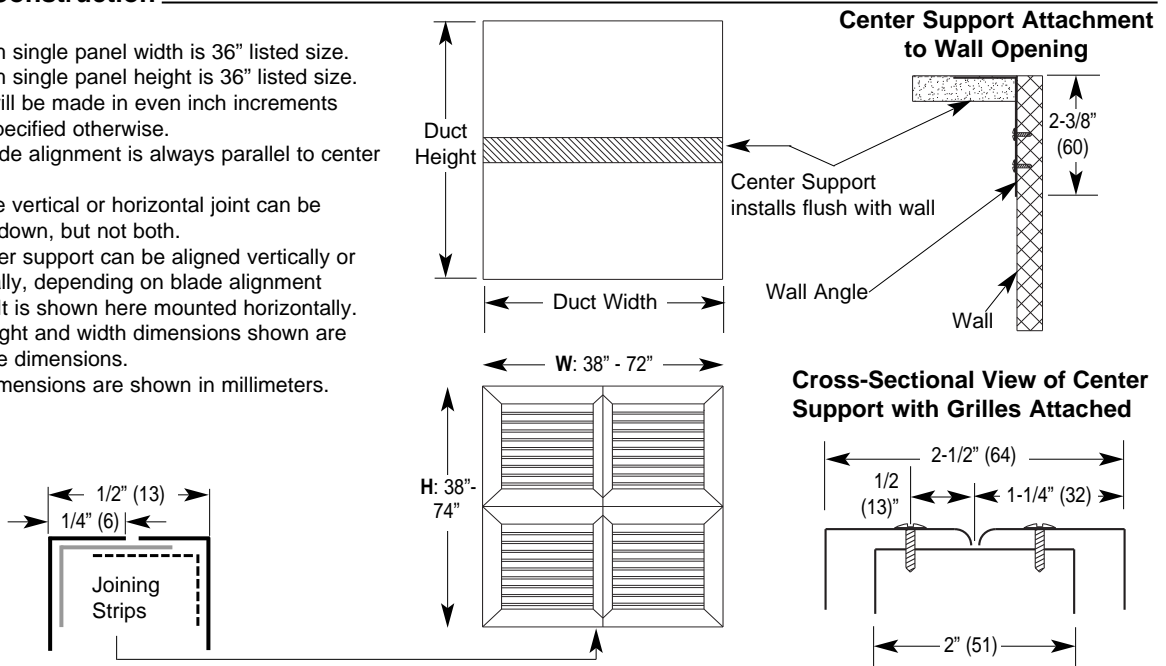

Multi-Panel Construction for the following Registers & Grilles

Steel
 Louvered Return RSLA, RTLA
 Perforated Return RSFA, RTFA

In-Line Construction

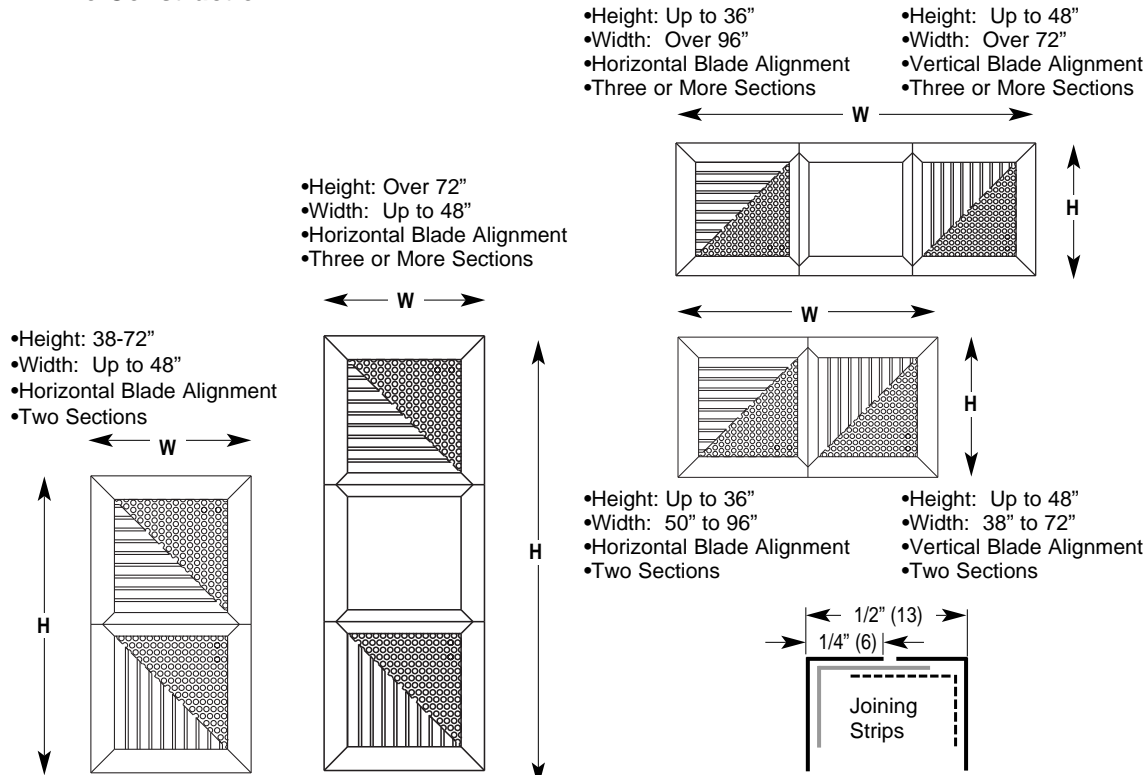

Notes:

1. Panels will be made in even inch increments unless specified otherwise.
2. Dimensions shown are listed size dimensions.
3. Max. blade length on louvered face models is nominal 48".
4. Panels are sheared and aligned with joining strips.

Ganged Construction

Notes:

1. Either the vertical or horizontal joint can be sheared down, but not both.
2. Maximum single panel width is 48" listed size.
3. Maximum blade length on louvered face models is listed size 48".
4. Maximum single panel height is 36" listed size.
5. Panels are made in even inch increments unless specified otherwise.
6. Blade alignment is always parallel to center support.
7. The center support can be aligned vertically or horizontally, depending on the blade alignment desired. It is shown here mounted horizontally.
8. Grille dimensions shown are listed size dimensions.

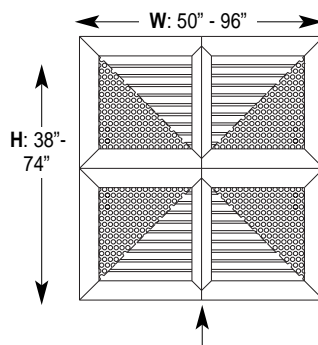
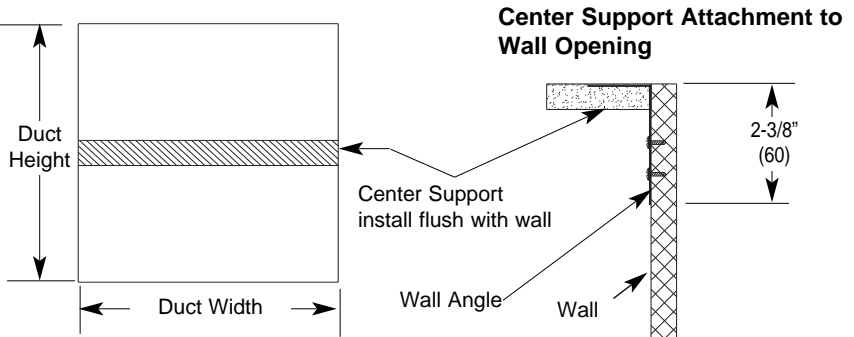
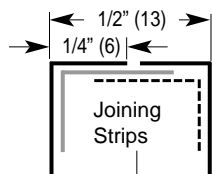

Cross-Sectional View of Center Support with Grilles Attached

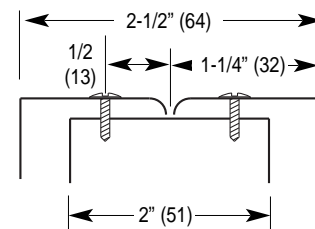

Multi-Panel In-Line Construction

Notes:

1. Maximum single panel width and height is 48" nominal size, regardless of blade alignment.
2. Panels are made in even inch increments unless specified otherwise.
3. Front blade alignment is as pictured.
4. Grille dimensions shown are nominal dimensions.
5. Panel flanges are sheared and aligned with joining strips.

- Height: 50-96"
- Width: Up to 48"
- Two Sections
- Any Blade Alignment

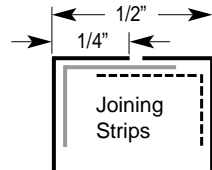
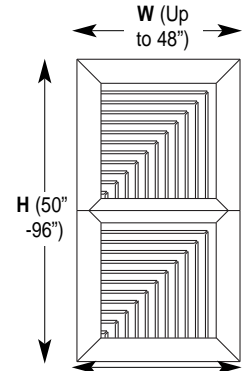

- Height: Over 96"
- Width: Up to 48"
- Three or more Sections
- Any Blade Alignment

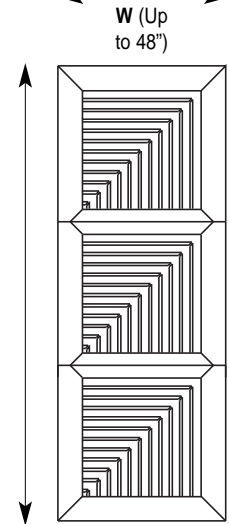

- Height: Up to 48"
- Width: 50" - 96"
- (Two Sections)
- Any Blade Alignment

- Height: Up to 48"
- Width: Over 96"
- Three or more Sections
- Any Blade Alignment

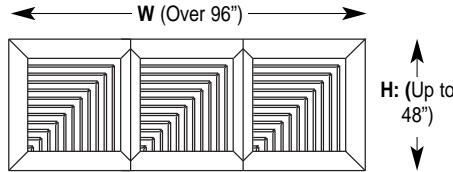
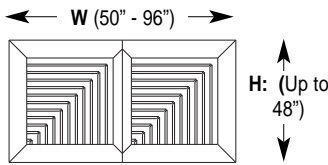

Multi-Panel Ganged Construction

Notes:

1. Maximum single panel width and height are 48" nominal size.
2. Panels are made in even inch increments unless specified otherwise.
3. Front blade alignment is always parallel to center support.
4. Either the vertical or horizontal joint can be sheared down, but not both.
5. The center support can be aligned vertically or horizontally, depending on blade alignment desired.
6. Grille dimensions shown are nominal dimensions.

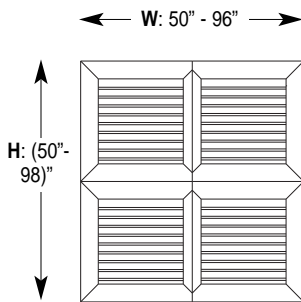

Cross-Sectional View of Center Support

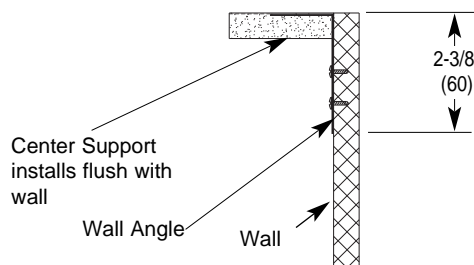
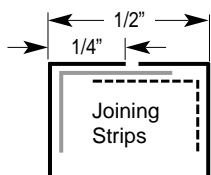
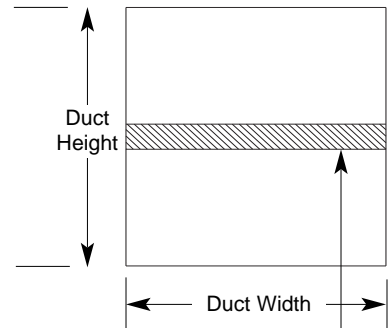
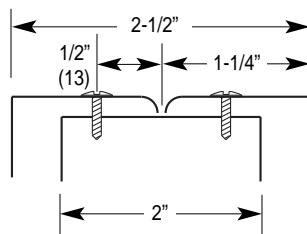

Center Support Mounted flush with wall (Shown aligned horizontally).

Sq. & Rect. Registers & Grilles

All Sections of Butted Grilles or Registers will be made in Listed Sizes as Standard.

STANDARD REGISTERS AND GRILLES

Applies to all models except louvered return air registers and grilles and door partition grilles.
Registers and grilles over 36" x 36" butting two or more grilles together.

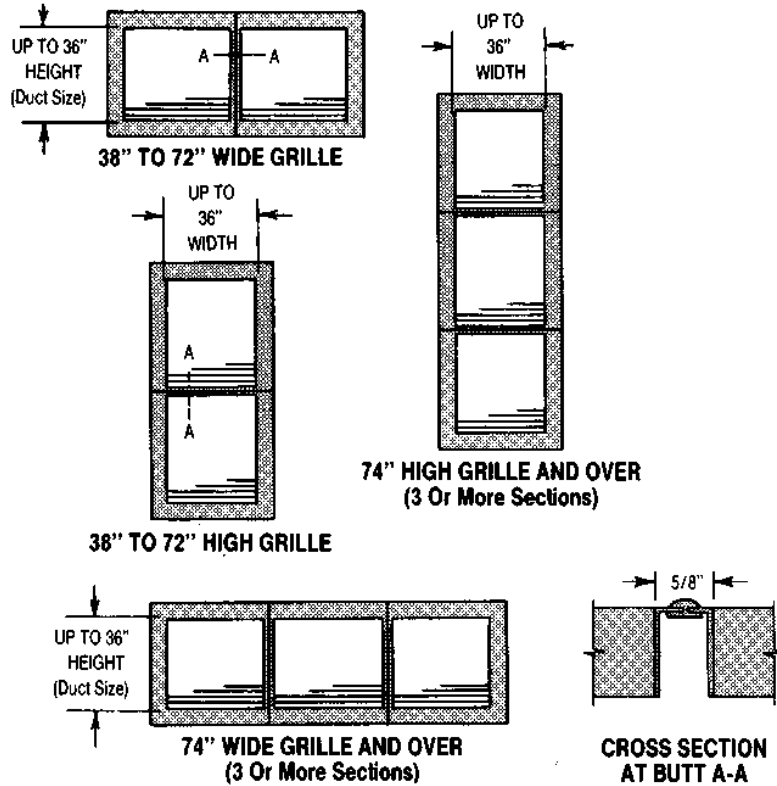

GRILLES AND REGISTERS HAVING FOUR SECTIONS AND OVER

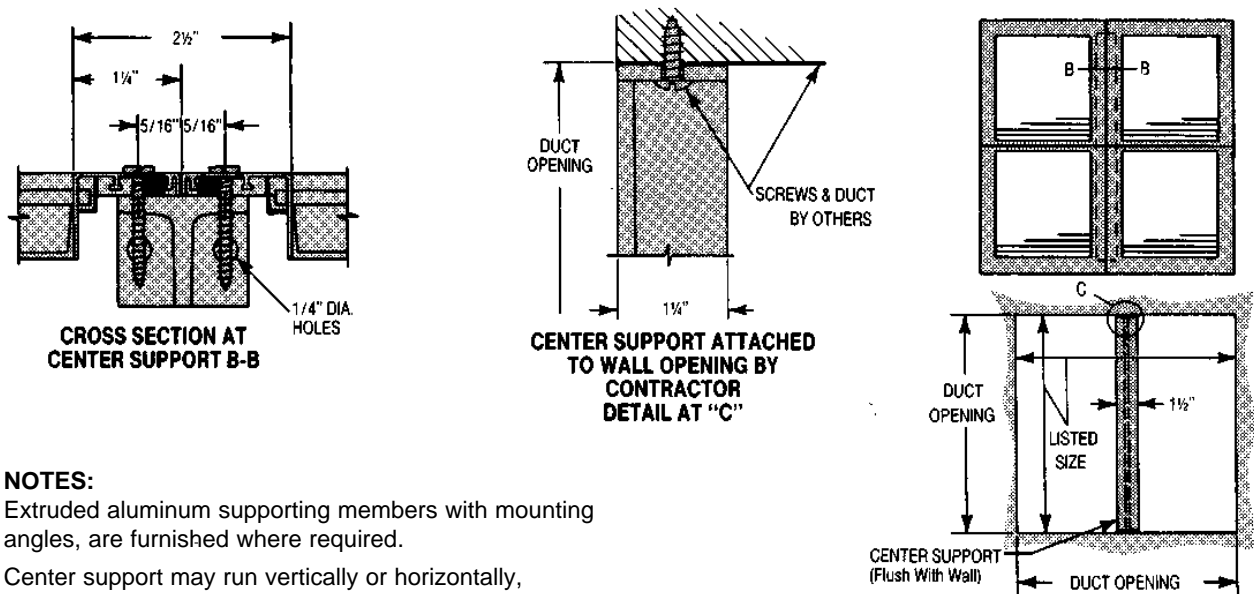

NOTES:

Extruded aluminum supporting members with mounting angles, are furnished where required.

Center support may run vertically or horizontally, depending upon combination of grilles used.

Combination of panels will be furnished to fit duct opening with satisfactory clearance.

Screw Hole Location for the following Registers & Grilles

	<u>Steel</u>	<u>Aluminum</u>	<u>Stainless Steel</u>
Single Deflection	RSSB, RTSB	RASM, RNSM	RLSB, RMSB, RKSB
Double Deflection	RSDB, RTDB	RADM, RNDM	RLDB, RMDB, RKDB
0° Fixed Return	RSRB, RTRB	RARM, RNRM	RLRB, RMRB, RKRB
45° Fixed Return	RSAB, RTAB	RAAM, RNAM	RLAB, RMAB, RKAB
Louvered Return	RSLA, RTLA	-----	-----
Perforated Return	RSFA, RTFA	RAFM, RNFM	-----

Notes:

- Screw holes on the face are standard on Registers and Grilles.
- Steel R&G can be ordered without screw holes, for use with concealed hangers (Opt. N).
- The screw holes is 5/32" in diameter.
- Each Register or Grille is provided with the appropriate number of screws as standard.
- The standard screw is #8 x 1-1/4" pan head screw, with a flat blade head.
- Tamper-proof screws are available as an option (Opt. B).

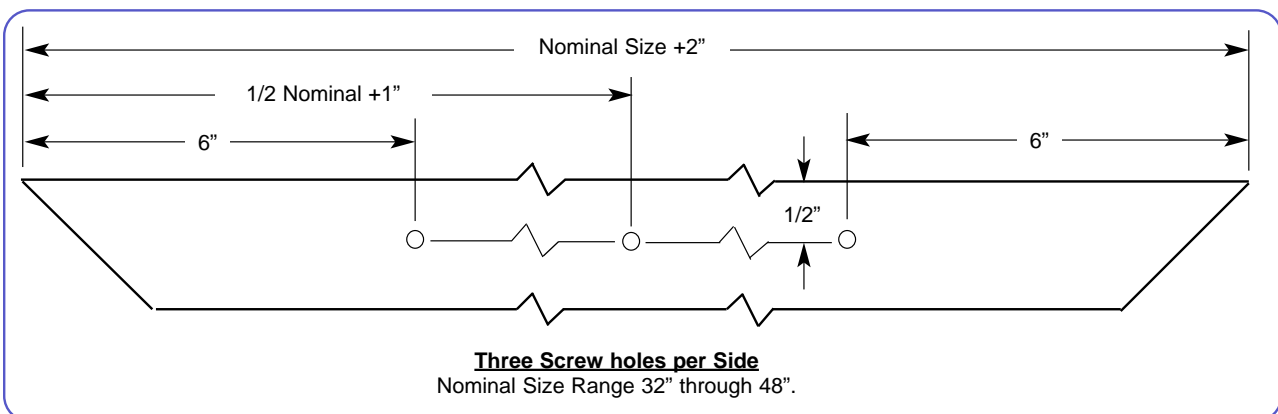
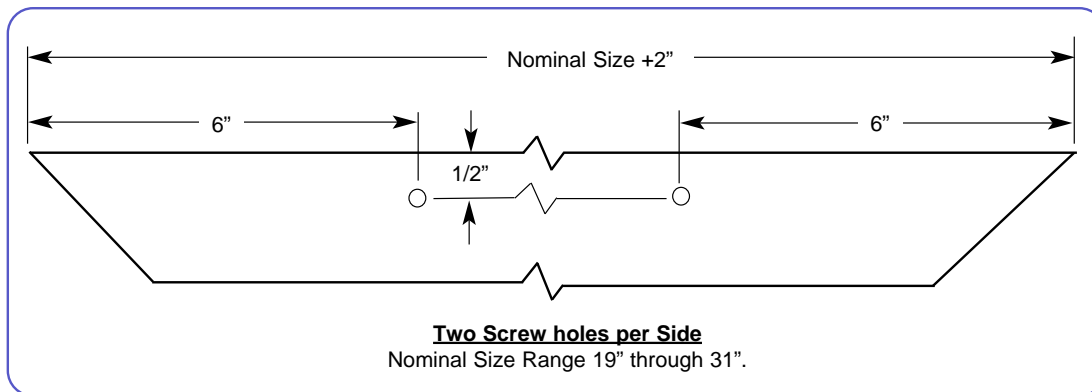
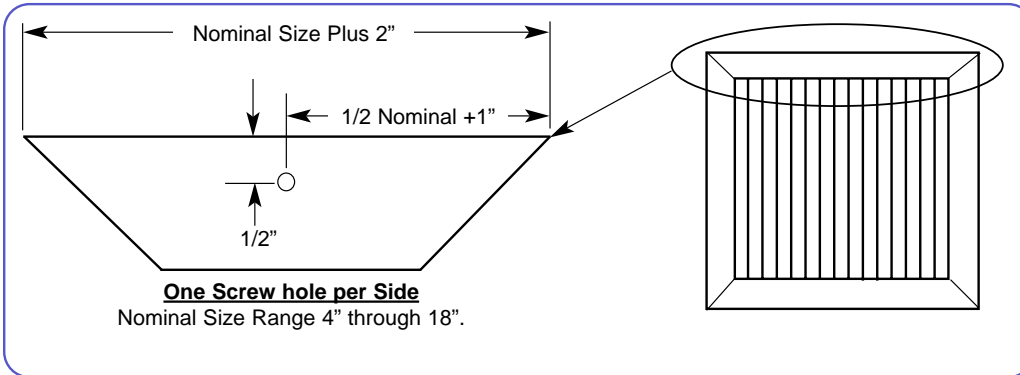

Sq. & Rect. Registers & Grilles