

SUPPLY GRILLES

SINGLE DEFLECTION

The single deflection supply grille is constructed from extruded aluminum. The frame is flat with sharp square edges to harmonize with modern aesthetical designs. The single row of teardrop shaped bars pivot at the front to provide uniform appearance regardless of angle of blade setting. Bars can be adjusted to provide directional control of the airstream in one or two directions. Gaskets are provided to prevent leakage around the frame.

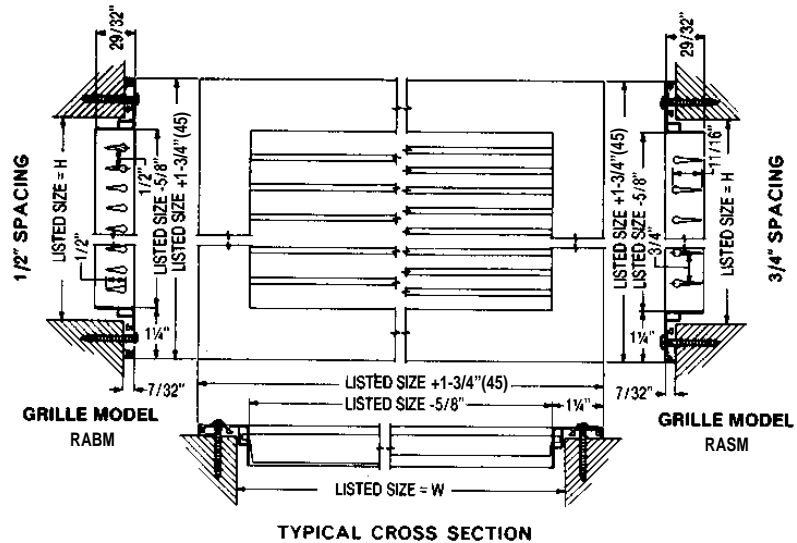
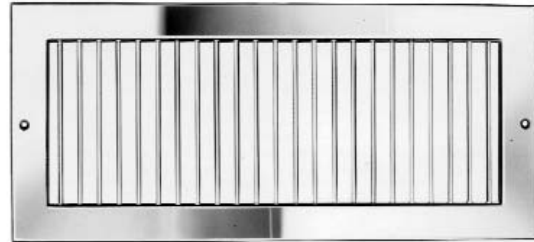

MODEL NOS.

Blade Spacing	Front Blades	
	Horizontal	Vertical
3/4"	RASMH	RASMV
1/2"	RABMH	RABMV

Sq. & Rect. Registers & Grilles

SUPPLY REGISTERS

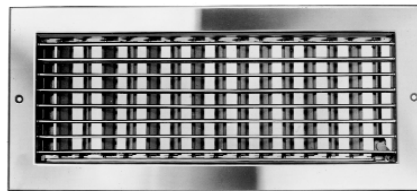

SINGLE DEFLECTION

The single deflection supply registers combine a single deflection grille with an opposed blade damper. The damper is extruded aluminum. Damper blades are gang operated by a key which can be removed after balancing. The damper assures even distribution of air across the grille face as well as positive volume control. The register is furnished with a gasket to prevent leakage around the frame.

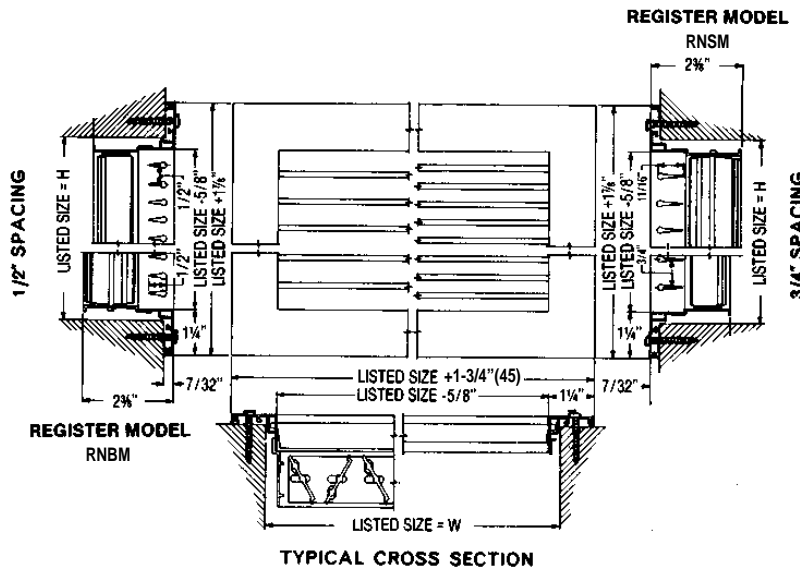

MODEL NOS.

With Aluminum Dampers		
Blade Spacing	Front Blades	
	Horizontal	Vertical
3/4"	RNSMH	RNSMV
1/2"	RNBMH	RNBMV

▼ **MODEL NUMBERING SYSTEM -**

M-Series Extruded Aluminum Single Deflection Supply Registers & Grilles

OPTIONS: (Must Be Present In Order Shown, Left-Justified, Default Is Standard and Applies if Not Entry is Made)

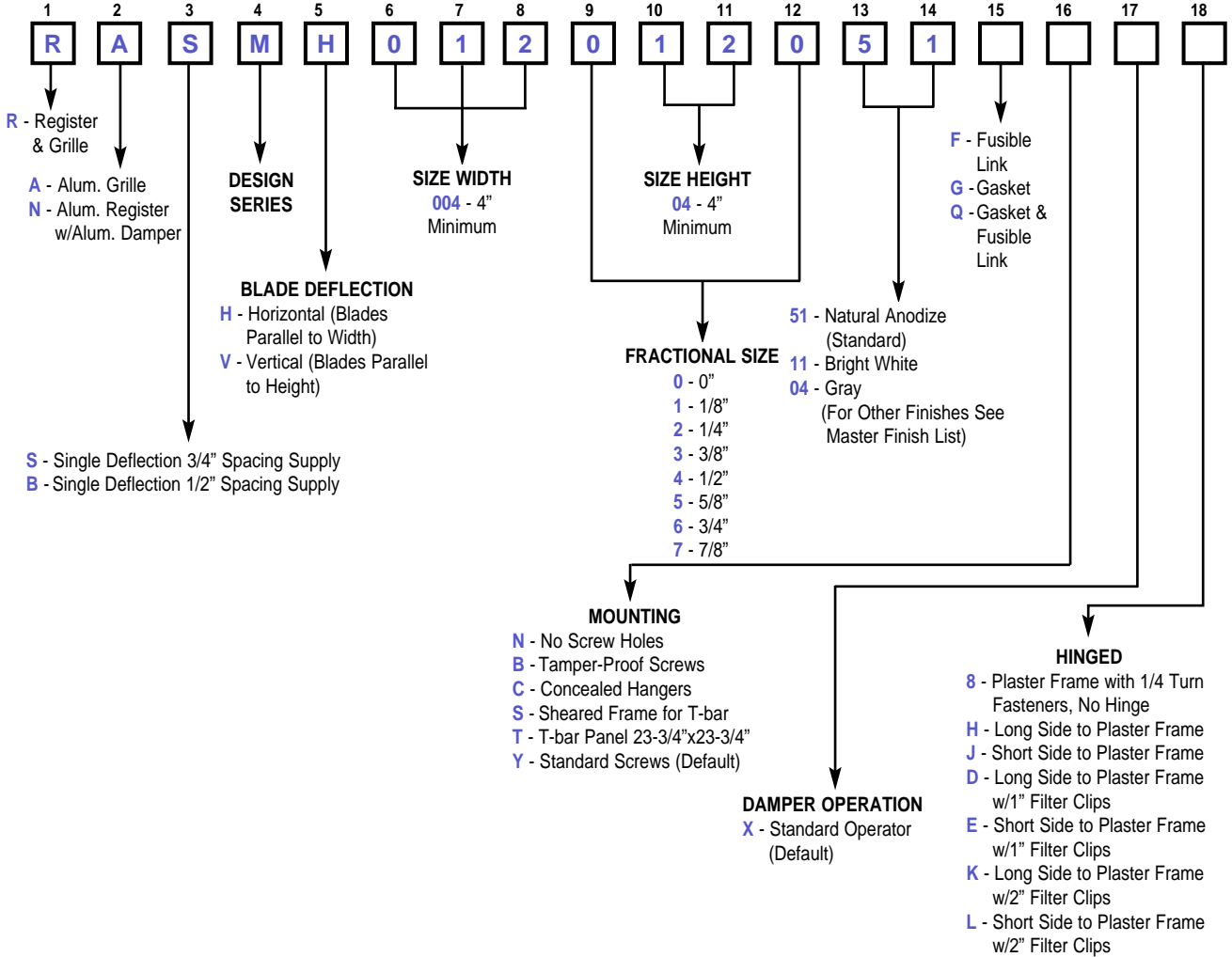

Sq. & Rect. Registers & Grilles

CFM	SIZES W x H (Wide x High)	8 x 4			10 x 4			8 x 6 10 x 5 12 x 4			10 x 6 12 x 5 14 x 4 18 x 4			12 x 6 14 x 5 18 x 4			10 x 8 14 x 6 16 x 5 18 x 5 20 x 4 22 x 4		
		0	22	45	0	22	45	0	22	45	0	22	45	0	22	45	0	22	45
50	Blade Settings °	8	6	5															
	Throw	4.5	2.5	1.0															
	Drop	335	385	420															
	Velocity Static Pressure	.009	.009	.009															
75	Throw	12	10	8	10	9	7	9	8	7	8	7	6						
	Drop	5.5	4.0	3.0	5.0	4.0	3.0	5.0	4.0	3.0	5.0	4.0	3.0						
	Velocity	500	580	630	400	460	495	330	380	415	280	325	355						
	Static Pressure	.015	.021	.025	.010	.013	.015	.009	.009	.011	.009	.009	.009						
100	Throw	16	13	11	14	12	10	12	11	9	11	10	8	10	9	7			
	Drop	5.0	4.0	3.5	6.0	4.5	4.0	7.0	5.0	3.5	7.0	4.5	3.5	6.0	5.0	3.55			
	Velocity	670	770	840	530	610	660	440	505	550	375	430	470	290	335	365			
	Static Pressure	.028	.037	.044	.017	.023	.027	.012	.016	.019	.009	.011	.013	.009	.009	.009			
125	Throw	19	16	14	17	15	12	16	14	11	14	12	10	13	11	9	12	10	8
	Drop	6.5	5.0	4.0	6.5	5.0	4.0	7.0	5.5	4.0	7.0	5.0	4.0	7.5	5.5	4.0	7.5	5.5	4.0
	Velocity	835	960	1050	665	760	825	550	630	685	475	540	585	360	420	455	325	375	405
	Static Pressure	.043	.057	.068	.027	.036	.042	.018	.025	.029	.014	.018	.022	.009	.011	.013	.009	.009	.010
150	Throw	23	20	17	20	18	15	19	16	13	17	14	12	15	13	11	14	12	10
	Drop	7.0	5.5	4.5	7.0	5.5	4.5	7.5	5.5	4.5	7.5	5.5	4.5	7.5	5.5	4.5	8.0	5.5	4.5
	Velocity	1000	1150	1260	800	915	990	660	760	820	560	645	705	435	500	545	390	450	485
	Static Pressure	.062	.081	.098	.04	.052	.061	.027	.036	.042	.019	.026	.031	.016	.018	.018	.009	.013	.015
175	Throw	27	23	19	24	21	17	22	19	16	20	17	14	18	15	13	16	14	12
	Drop	8.0	6.0	5.0	8.0	6.0	4.5	8.0	6.5	4.5	8.0	6.0	4.5	8.5	6.5	5.0	8.0	6.0	5.0
	Velocity	1170	1350	1470	930	1070	1155	770	885	955	655	755	821	510	585	640	455	525	567
	Static Pressure	.084	.113	.134	.054	.071	.082	.037	.048	.057	.027	.036	.042	.016	.021	.026	.013	.017	.020
200	Throw	31	27	22	27	24	20	25	22	18	22	19	16	20	18	15	18	16	14
	Drop	8.5	7.0	5.0	8.5	7.0	5.5	8.5	6.5	5.5	8.0	6.5	5.0	8.5	7.0	5.5	8.5	6.5	5.5
	Velocity	1340	1540	1680	1060	1220	1320	880	1010	1090	750	880	940	580	670	730	520	600	650
	Static Pressure	.111	.147	.174	.070	.092	.107	.048	.063	.074	.035	.046	.055	.021	.028	.033	.017	.022	.026
225	Throw	35	30	25	31	27	23	28	25	20	25	22	18	23	20	16	21	18	15
	Drop	9.0	7.0	5.5	9.0	7.0	6.0	9.0	7.0	5.5	8.5	6.5	5.5	9.0	7.0	5.5	9.0	7.0	5.5
	Velocity	1500	1730	1890	1190	1370	1490	990	1140	1225	845	970	1055	655	750	820	585	675	730
	Static Pressure	.140	.186	.221	.087	.117	.138	.061	.079	.093	.044	.058	.069	.026	.035	.042	.021	.029	.033
250	Throw	39	33	27	35	30	25	32	28	23	28	24	20	26	22	18	24	20	17
	Drop	10.0	7.5	6.0	10.0	7.5	6.0	10.0	7.5	6.0	9.5	7.5	6.0	10.0	7.5	6.0	10.0	7.5	6.0
	Velocity	1670	1930	2100	1330	1525	1650	1100	1265	1360	940	1080	1170	725	833	910	650	750	810
	Static Pressure	.172	.230	.272	.109	.146	.167	.075	.099	.115	.055	.072	.084	.032	.043	.051	.026	.035	.041
275	Throw	43	37		38	33	28	35	30	25	31	27	23	28	24	20	26	22	19
	Drop	10.5	8.0		10.5	8.0	6.5	10.5	8.0	6.5	10.0	8.0	6.0	10.5	8.0	6.5	10.5	7.5	6.5
	Velocity	1840	2120		1460	1680	1815	1210	1390	1495	1030	1185	1290	800	915	1000	715	825	890
	Static Pressure	.209	.273		.132	.174	.205	.091	.120	.139	.065	.086	.104	.040	.051	.062	.031	.042	.049
300	Throw	47			41	35	30	38	33	27	34	29	25	30	26	22	28	24	21
	Drop	11.0			10.5	8.5	7.0	11.0	8.5	7.0	10.5	8.0	6.5	10.5	8.0	6.5	10.5	8.0	6.5
	Velocity	2010			1590	1830	1980	1320	1520	1630	1120	1290	1405	870	1000	1090	780	900	972
	Static Pressure	.252			.156	.207	.244	.107	.144	.164	.077	.104	.121	.047	.062	.074	.038	.050	.058
325	Throw				44	38		40	35	30	37	32	27	33	28	23	30	26	23
	Drop				11.0	9.0		11.0	8.5	7.0	11.0	8.5	7.0	11.0	8.5	7.0	10.5	8.5	7.0
	Velocity				1730	1980		1430	1645	1765	1220	1400	1525	945	1080	1185	845	975	1055
	Static Pressure				.186	.244		.126	.167	.193	.092	.121	.145	.055	.072	.086	.044	.059	.069
350	Throw				47			44	38	32	40	35	29	36	30	25	32	28	25
	Drop				11.5			11.5	9.5	7.5	11.5	9.0	7.0	11.5	9.0	7.0	11.0	8.5	7.5
	Velocity				1860			1540	1770	1900	1310	1510	1640	1020	1165	1275	910	1050	1135
	Static Pressure				.214			.147	.194	.224	.106	.142	.165	.065	.083	.101	.051	.068	.078
375	Throw							47	41	34	42	37	31	38	33	27	35	31	28
	Drop							12.0	9.6	7.5	11.5	9.0	7.5	12.0	9.5	7.5	12.0	9.5	8.0
	Velocity							1650	1900	2035	1410	1620	1760	1090	1250	1365	975	1125	1215
	Static Pressure							.167	.224	.254	.122	.162	.192	.074	.096	.116	.059	.078	.091
400	Throw							50	45		45	39	33	41	36	29	38	33	31
	Drop							12.5	10.5		12.0	9.5	7.5	12.5	10.0	7.5	12.5	9.5	8.5
	Velocity							1760	2040		1500	1725	1875	1160	1330	1455	1040	1200	1295
	Static Pressure							.192	.254		.140	.185	.218	.083	.109	.131	.066	.088	.104
425	Throw							53			48	41	35	43	38	32	40	35	33
	Drop							13.0			12.5	10.0	8.0	13.0	10.0	8.0	12.5	9.5	9.0
	Velocity							1870			1600	1832	1990	1235	1415	1550	1105	1275	1375
	Static Pressure							.216			.158	.207	.247	.093	.123	.148	.07	.101	.117
450	Throw										51	44	37	46	40	34	42	37	35
	Drop										13.5	10.5	8.0	13.0	10.5	8.5	13.0	10.0	9.0
	Velocity										1690	1940	2110	1310	1500	1640	1170	1350	1460
	Static Pressure										.177	.233	.275	.106	.140	.165	.084	.113	.132
475	Throw										53	46		48	42	36	45	38	36
	Drop										14.0	10.5		14.0	11.0	8.5	13.5	10.5	9.0
	Velocity										1780	2050		1380	1580	1730	1235	1425	1540
	Static Pressure										.196	.260		.118	.154	.186	.093	.125	.147
500	Throw										55			50	44	37	47	40	37
	Drop										14.0			14.0	11.0	8.5	14.0	10.5	9.0

CFM	SIZES W x H (Wide x High)	10 x 10 12 x 8 16 x 6 20 x 5 24 x 4			12 x 10 14 x 8 / 18 x 6 20 x 6 / 22 x 5 24 x 5 28 x 4 30 x 4			12 x 12 / 14 x 10 16 x 8 / 18 x 8 22 x 6 / 24 x 6 28 x 5 30 x 5 36 x 4			14 x 12 / 16 x 10 18 x 10 / 20 x 8 22 x 8 / 28 x 6 30 x 6 36 x 5 48 x 4			14 x 14 16 x 12 / 18 x 12 20 x 10 / 22 x 10 24 x 8 36 x 6 48 x 5			16 x 14 / 16 x 16 18 x 14 / 20 x 12 24 x 10 / 22 x 12 20 x 8 30 x 8 48 x 6		
		Blade Settings °	0	22	45	0	22	45	0	22	45	0	22	45	0	22	45	0	22
50	Throw																		
	Drop																		
	Velocity Static Pressure																		
75	Throw																		
	Drop																		
	Velocity Static Pressure																		
100	Throw																		
	Drop																		
	Velocity Static Pressure																		
125	Throw	11																	
	Drop	7.5																	
	Velocity Static Pressure	270 .009																	
150	Throw	13	11																
	Drop	8.0	6.0																
	Velocity Static Pressure	325 .009	365 .009																
175	Throw	15	13	11															
	Drop	8.5	7.0	5.5															
	Velocity Static Pressure	375 .009	430 .011	470 .013															
200	Throw	17	15	12															
	Drop	9.0	7.0	5.5															
	Velocity Static Pressure	430 .011	490 .015	535 .018															
225	Throw	19	17	14															
	Drop	9.5	7.5	5.5															
	Velocity Static Pressure	485 .014	550 .018	605 .022															
250	Throw	21	19	15															
	Drop	9.5	8.0	6.0															
	Velocity Static Pressure	540 .018	610 .023	670 .028															
275	Throw	23	20	17															
	Drop	10.0	8.0	6.0															
	Velocity Static Pressure	595 .022	675 .018	740 .024															
300	Throw	26	22	18															
	Drop	11.0	8.0	6.0															
	Velocity Static Pressure	645 .026	735 .033	805 .040															
325	Throw	28	24	19															
	Drop	11.5	8.5	6.5															
	Velocity Static Pressure	700 .030	795 .039	870 .047															
350	Throw	30	26	21															
	Drop	11.5	9.0	6.5															
	Velocity Static Pressure	755 .035	855 .045	940 .055															
375	Throw	32	28	23															
	Drop	12.0	9.5	7.0															
	Velocity Static Pressure	810 .041	915 .051	1005 .062															
400	Throw	35	30	25															
	Drop	12.5	9.5	7.5															
	Velocity Static Pressure	865 .046	975 .059	1075 .071															
425	Throw	37	32	27															
	Drop	12.5	10.0	7.5															
	Velocity Static Pressure	920 .052	1040 .066	1140 .079															
450	Throw	39	34	28															
	Drop	13.5	10.5	8.0															
	Velocity Static Pressure	970 .058	1100 .075	1205 .088															
475	Throw	40	36	29															
	Drop	13.5	11.0	8.0															
	Velocity Static Pressure	1025 .064	1160 .083	1275 .101															
500	Throw	42	38	30															
	Drop	13.5	11.5	8.0															
	Velocity Static Pressure	1080 .072	1220 .092	1340 .111															
550	Throw	46	40	32															
	Drop	14.0	11.5	8.5															
	Velocity Static Pressure	1190 .087	1345 .111	1475 .135															

CFM	SIZES W x H (Wide x High)	10 x 8 14 x 8 16 x 5 18 x 5 20 x 4 22 x 4			10 x 10 12 x 8 16 x 6 20 x 5 24 x 4			12 x 10 14 x 8 / 18 x 6 20 x 6 / 22 x 5 24 x 5 28 x 4 30 x 4			12 x 12 / 14 x 10 16 x 8 / 18 x 8 22 x 6 / 24 x 6 28 x 5 30 x 5 36 x 4			14 x 12 / 16 x 10 18 x 10 / 20 x 8 22 x 8 / 28 x 6 30 x 6 36 x 5 48 x 4			14 x 14 16 x 12 / 18 x 12 20 x 10 / 22 x 10 24 x 8 36 x 6 48 x 5		
		Blade Settings °	0	22	45	0	22	45	0	22	45	0	22	45	0	22	45	0	22
600	Throw	56	48	39	50	44	36	46	39	33	42	35	30	40	33	27	36	31	25
	Drop	15.5	12.0	9.0	14.5	12.0	9.0	15.0	11.5	9.0	15.5	11.5	9.0	16.5	12.0	9.0	16.5	12.5	9.0
	Velocity	1560	1795	1950	1295	1465	1610	1080	1250	1345	840	960	1060	720	830	900	610	700	815
	Static Pressure	.150	.199	.235	.104	.133	.160	.072	.096	.112	.044	.057	.070	.032	.043	.050	.023	.030	.041
650	Throw	60	52	42	55	47	39	50	42	35	45	38	32	43	35	29	38	34	27
	Drop	15.5	12.5	9.0	16.0	12.5	9.5	15.5	11.5	9.5	16.0	12.0	9.5	17.0	12.5	9.5	16.5	13.0	9.5
	Velocity	1690	1945	2110	1405	1585	1740	1170	1350	1460	910	1040	1145	780	900	975	660	755	885
	Static Pressure	.177	.234	.275	.121	.155	.188	.084	.113	.132	.051	.066	.080	.038	.050	.059	.027	.035	.048
700	Throw		56	45	60	50	42	54	45	37	48	41	35	46	38	31	41	36	29
	Drop		13.0	10.0	16.5	12.5	9.5	16.0	12.0	9.5	17.0	12.5	10.0	17.5	12.5	10.0	17.0	13.5	9.5
	Velocity		2095	2275	1510	1710	1875	1260	1455	1570	980	1120	1230	840	965	1050	710	815	960
	Static Pressure		.268	.320	.142	.182	.217	.098	.131	.152	.060	.077	.093	.044	.057	.068	.031	.041	.057
750	Throw		60	48		55	46	57	48	40	52	44	37	48	41	34	44	38	31
	Drop		14.0	10.5		14.0	10.5	16.5	13.0	10.0	17.5	13.5	10.0	18.0	13.5	10.0	18.0	13.5	10.0
	Velocity		2240	2435		1830	2010	1350	1560	1680	1050	1200	1320	900	1035	1130	760	875	1030
	Static Pressure		.310	.361		.207	.253	.113	.150	.174	.068	.088	.107	.050	.065	.078	.036	.047	.065
800	Throw					58	48	61	52	43	56	47	40	52	43	36	47	41	34
	Drop					14.5	11.0	17.5	13.5	10.5	17.5	14.0	11.0	18.5	13.5	10.5	18.5	14.5	10.5
	Velocity					1950	2150	1440	1665	1905	1190	1280	1410	960	1105	1205	810	930	1105
	Static Pressure					.235	.277	.128	.170	.225	.087	.102	.122	.057	.075	.090	.041	.054	.075
900	Throw								58	49	63	53	45	59	48	41	53	46	38
	Drop								14.5	11.0	18.5	14.5	11.5	20.0	14.5	11.5	19.5	14.5	11.0
	Velocity								1870	2130	1330	1440	1584	1080	1240	1350	915	1050	1250
	Static Pressure								.216	.277	.109	.128	.154	.072	.094	.113	.051	.068	.096
1000	Throw													59	50		59	51	43
	Drop													16.0	12.5		15.5	12.0	12.0
	Velocity													1600	1760		1380	1500	1395
	Static Pressure													.158	.192		.118	.140	.120
1100	Throw													65	56		60	49	46
	Drop													16.0	13.5		16.5	12.5	12.0
	Velocity													1760	1940		1520	1650	1540
	Static Pressure													.192	.233		.144	.167	.147
1200	Throw																65	53	50
	Drop																17.0	13.0	12.5
	Velocity																1655	1800	1685
	Static Pressure																.169	.200	.175
1300	Throw																58	54	54
	Drop																14.5	17.5	13.0
	Velocity																1950	1515	1830
	Static Pressure																.235	.142	.207
1400	Throw																		58
	Drop																		14.5
	Velocity																		1975
	Static Pressure																		.242
1500	Throw																		
	Drop																		
	Velocity																		
	Static Pressure																		
1600	Throw																		
	Drop																		
	Velocity																		
	Static Pressure																		
1700	Throw																		
	Drop																		
	Velocity																		
	Static Pressure																		
1800	Throw																		
	Drop																		
	Velocity																		
	Static Pressure																		
1900	Throw																		
	Drop																		
	Velocity																		
	Static Pressure																		
2000	Throw																		
	Drop																		
	Velocity																		
	Static Pressure																		
2400	Throw																		
	Drop																		
	Velocity																		
	Static Pressure																		
2800	Throw																		
	Drop																		
	Velocity																		
	Static Pressure																		
3200	Throw																		
	Drop																		
	Velocity																		
	Static Pressure																		

Sq. & Rect. Registers & Grilles

CFM	SIZES W x H (Wide x High)	16 x 14 / 16 x 16 18 x 14 / 20 x 12 22 x 12 / 24 x 10			18 x 16 / 20 x 14 20 x 16 / 22 x 24			18 x 18 / 20 x 18 22 x 16 / 24 x 14 24 x 16 / 28 x 12			20 x 20 22 x 18 / 24 x 18 28 x 14 / 30 x 14			28 x 18 30 x 16 / 36 x 14			30 x 18 36 x 16 48 x 12 60 x 10		
		0	22	45	0	22	45	0	22	45	0	22	45	0	22	45	0	22	45
600	Blade Settings °	0	22	45	0	22	45	0	22	45	0	22	45	0	22	45	0	22	45
	Throw	32	27	23	29	24	21												
	Drop	18.0	13.0	10.0	17.5	13.0	10.5												
	Velocity	475	545	595	395	455	495												
650	Static Pressure	.014	.018	.022	.010	.013	.016												
	Throw	35	30	25	31	27	23												
	Drop	18.0	13.5	10.5	18.0	14.5	11.0												
	Velocity	515	590	645	430	495	535												
700	Static Pressure	.017	.021	.026	.011	.016	.018												
	Throw	37	32	27	33	29	24												
	Drop	18.0	14.0	10.5	18.5	14.5	11.0												
	Velocity	555	635	695	460	530	580												
750	Static Pressure	.019	.025	.029	.013	.017	.021												
	Throw	40	34	29	36	31	26	32	27	23									
	Drop	19.0	14.0	11.5	18.5	14.5	11.0	20.0	15.0	12.0									
	Velocity	595	680	740	495	570	620	390	450	485									
800	Static Pressure	.022	.029	.034	.015	.020	.024	.009	.012	.014									
	Throw	43	36	31	39	33	28	35	30	25	31	27	24						
	Drop	20.0	14.5	11.5	20.5	15.0	11.5	20.5	15.5	12.0	20.5	15.5	12.5						
	Velocity	635	725	790	525	610	660	420	485	525	375	430	470						
900	Static Pressure	.026	.032	.039	.017	.023	.027	.011	.014	.017	.009	.011	.013						
	Throw	48	41	35	44	37	31	39	33	28	36	30	28	35	28	24			
	Drop	20.5	15.5	11.5	20.5	15.5	12.0	21.0	16.5	13.0	21.5	16.0	14.0	25.0	17.0	13.5			
	Velocity	715	815	990	595	685	740	470	545	590	425	485	530	350	400	435			
1000	Static Pressure	.031	.041	.061	.022	.029	.034	.013	.018	.021	.011	.014	.017	.009	.010	.012			
	Throw	54	45	38	48	40	35	44	37	32	40	34	31	38	32	27			
	Drop	21.5	16.5	12.0	22.0	16.0	13.0	23.5	17.0	14.0	23.0	16.5	14.0	25.5	18.0	14.5			
	Velocity	795	905	1090	660	760	825	520	605	655	470	540	590	385	445	485			
1100	Static Pressure	.039	.050	.074	.027	.036	.042	.017	.022	.026	.013	.018	.021	.009	.012	.014			
	Throw	59	50	42	54	44	38	47	40	35	43	36	33	41	35	29	37	32	26
	Drop	23.0	17.0	12.0	23.0	17.0	13.0	24.0	17.5	14.0	23.5	17.0	14.5	25.5	18.5	14.5	25.5	19.5	14.5
	Velocity	870	1000	1180	725	835	910	575	665	720	520	590	645	425	490	535	355	410	445
1200	Static Pressure	.047	.062	.086	.032	.043	.051	.020	.027	.032	.017	.021	.026	.011	.015	.018	.009	.010	.012
	Throw		54	45	57	48	41	51	44	37	46	40	35	44	37	32	41	35	28
	Drop		18.0	13.0	23.0	17.5	14.0	24.5	18.5	15.0	23.5	18.0	14.5	26.5	19.0	15.0	27.5	20.0	15.0
	Velocity		1090	1280	790	910	990	625	725	785	565	645	705	465	535	580	390	450	485
1300	Static Pressure		.074	.012	.039	.051	.061	.024	.032	.038	.019	.026	.030	.013	.018	.021	.009	.012	.014
	Throw		58	48	63	53	45	56	48	40	50	43	37	48	41	35	44	37	31
	Drop		19.0	13.5	24.0	18.5	14.5	27.0	19.5	15.0	24.5	18.5	14.5	27.5	20.0	15.5	28.5	20.0	16.0
	Velocity		1180	1380	860	990	1070	675	785	850	610	700	765	505	580	630	420	485	525
1400	Static Pressure		.086	.118	.046	.061	.071	.028	.038	.045	.023	.030	.036	.016	.021	.025	.011	.014	.017
	Throw		63	53		56	48	60	51	44	55	46	39	52	44	37	47	40	34
	Drop		19.5	14.5		19.0	15.0	27.5	20.0	16.0	27.0	18.5	15.0	28.5	20.5	15.5	28.5	21.0	16.0
	Velocity		1270	1475		1060	1155	730	845	915	660	755	825	540	625	680	455	525	570
1500	Static Pressure		.100	.135		.070	.083	.033	.044	.051	.027	.035	.042	.018	.024	.029	.013	.017	.020
	Throw					60	51		55	47	62	50	41	55	47	39	51	43	36
	Drop					19.5	15.5		21.0	16.5	29.0	19.5	15.0	29.0	21.0	16.0	28.5	22.0	16.5
	Velocity					1575	1235		905	980	705	810	880	580	645	725	490	560	610
1600	Static Pressure					.153	.079		.050	.060	.030	.041	.048	.021	.027	.032	.015	.019	.023
	Throw								55	45		53	45	60	50	41	55	46	38
	Drop								16.5	12.5		20.5	15.5	30.5	21.5	16.0	32.0	22.5	17.0
	Velocity								965	1045		865	940	620	710	775	520	600	650
1700	Static Pressure					.173	.107		.057	.067		.046	.055	.024	.031	.037	.017	.022	.026
	Throw								58	53		57	48		53	44	58	49	41
	Drop								17.0	12.5		21.0	16.5		22.5	17.0	33.5	23.0	17.5
	Velocity								1400	1025		920	1000		765	825	550	635	690
1800	Static Pressure								.121	.064		.052	.062		.035	.042	.018	.025	.029
	Throw								61	55		60	50		58	47	61	52	43
	Drop								17.5	12.5		22.0	16.5		24.0	18.0	34.0	23.5	18.0
	Velocity								1480	1175		970	1060		800	875	585	675	730
1900	Static Pressure								.136	.085		.058	.070		.040	.047	.021	.028	.033
	Throw											58			60	50		54	45
	Drop											18.5			24.0	18.0		24.0	18.0
	Velocity											1240			845	920		710	770
2000	Static Pressure											.094			.076		.031	.037	.041
	Throw											61			55			57	47
	Drop											18.5			17.5			24.0	18.5
	Velocity											1305			1175			750	810
2400	Static Pressure											.105			.085			.035	.041
	Throw																	64	56
	Drop														20.0			24.5	20.0
	Velocity														1165			895	975
2800	Static Pressure														.083			.049	.059
	Throw																		64
	Drop																	20.5	20.5
	Velocity																	1140	1140
3200	Static Pressure																		.079
	Throw																		70
	Drop																	21.0	21.0
	Velocity																	1300	1300
3200	Static Pressure																		.105

Multi-Panel Construction for the following Registers & Grilles

	Steel	Stainless Steel	Aluminum
Single Deflection	RSSB, RTSB	RLSB, RMSB, RKSB	RASM, RNSM
Double Deflection	RSDB, RTDB	RLDB, RMDB, RKDB	RADM, RNDM
0° Fixed Return	RSRB, RTRB	RLRB, RMRB, RKRB	RARM, RNRM
45° Fixed Return	RSAB, RTAB	RLAB, RMAB, RKAB	RAAM, RNAM

In-line Construction

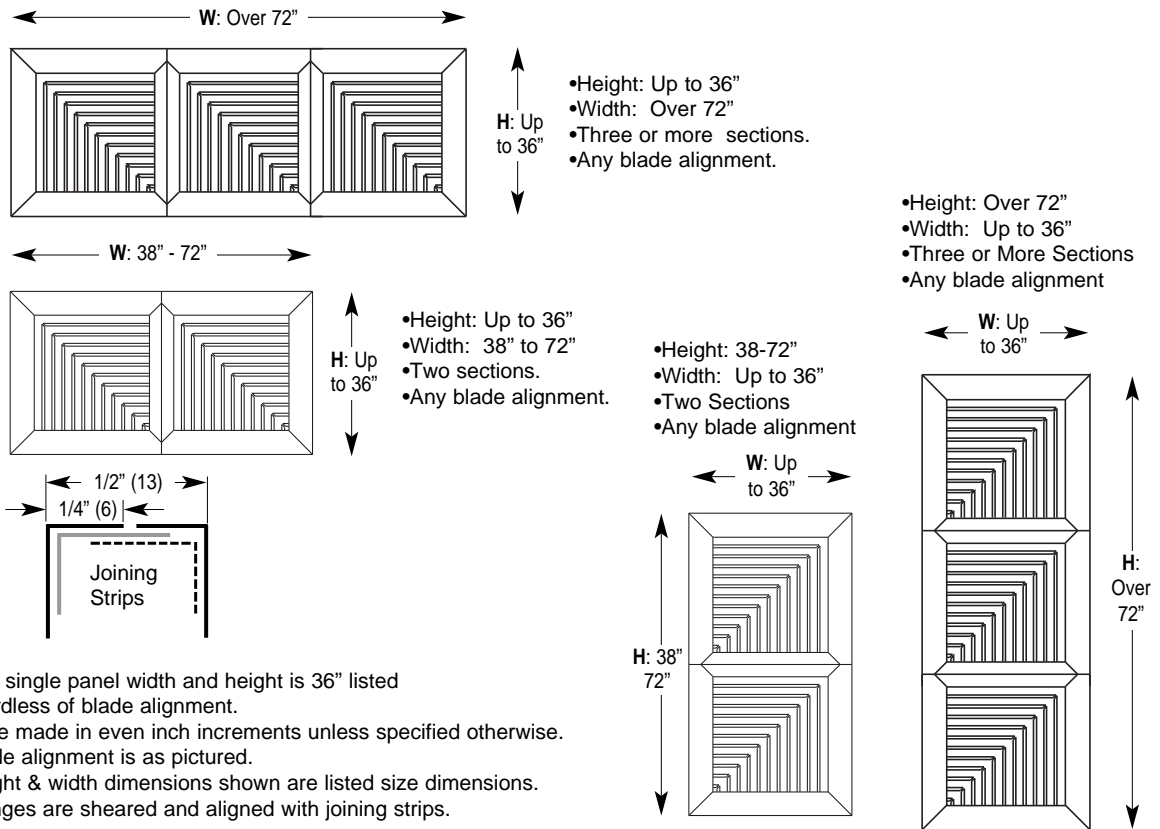

Notes:

1. Maximum single panel width and height is 36" listed size regardless of blade alignment.
2. Panels are made in even inch increments unless specified otherwise.
3. Front blade alignment is as pictured.
4. Grille height & width dimensions shown are listed size dimensions.
5. Panel flanges are sheared and aligned with joining strips.

Ganged Construction

Notes:

1. Maximum single panel width is 36" listed size.
2. Maximum single panel height is 36" listed size.
3. Panels will be made in even inch increments unless specified otherwise.
4. Front blade alignment is always parallel to center support.
5. Either the vertical or horizontal joint can be sheared down, but not both.
6. The center support can be aligned vertically or horizontally, depending on blade alignment desired. It is shown here mounted horizontally.
7. Grille height and width dimensions shown are listed size dimensions.
8. Metric dimensions are shown in millimeters.

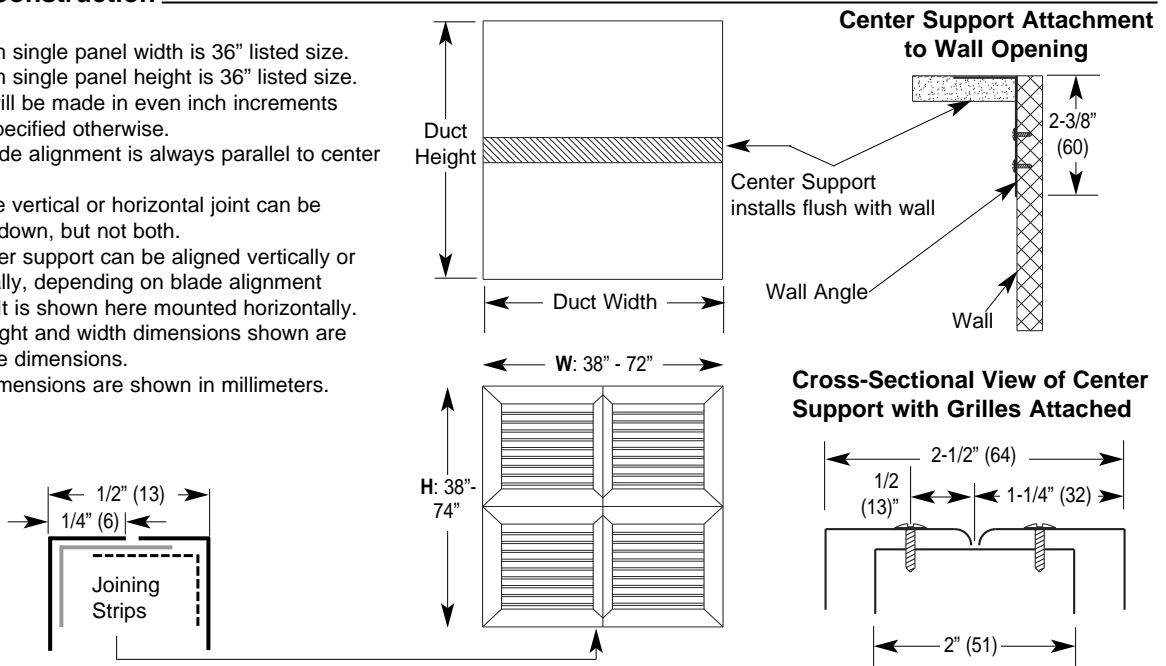

Multi-Panel Construction for the following Registers & Grilles

Steel
 Louvered Return RSLA, RTLA
 Perforated Return RSFA, RTFA

In-Line Construction

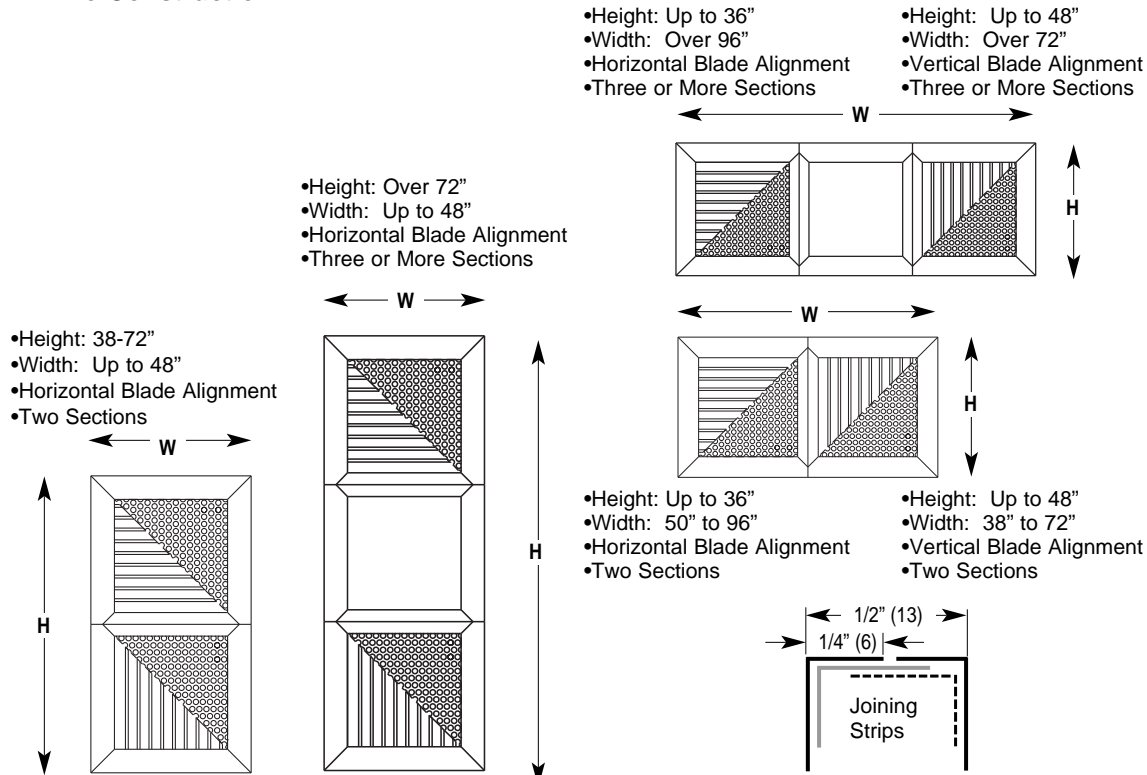

Notes:

1. Panels will be made in even inch increments unless specified otherwise.
2. Dimensions shown are listed size dimensions.
3. Max. blade length on louvered face models is nominal 48".
4. Panels are sheared and aligned with joining strips.

Ganged Construction

Notes:

1. Either the vertical or horizontal joint can be sheared down, but not both.
2. Maximum single panel width is 48" listed size.
3. Maximum blade length on louvered face models is listed size 48".
4. Maximum single panel height is 36" listed size.
5. Panels are made in even inch increments unless specified otherwise.
6. Blade alignment is always parallel to center support.
7. The center support can be aligned vertically or horizontally, depending on the blade alignment desired. It is shown here mounted horizontally.
8. Grille dimensions shown are listed size dimensions.

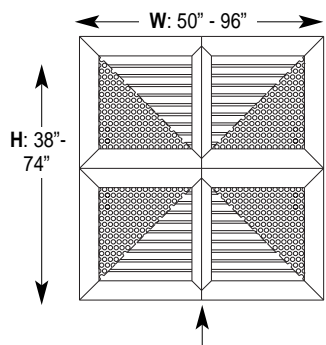
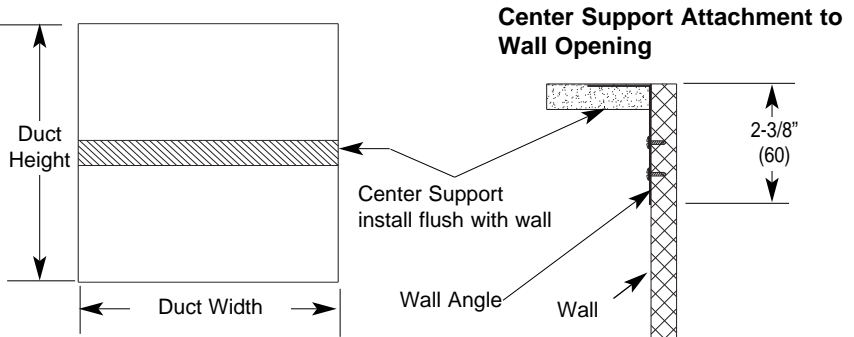
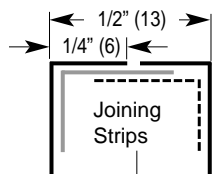

Cross-Sectional View of Center Support with Grilles Attached

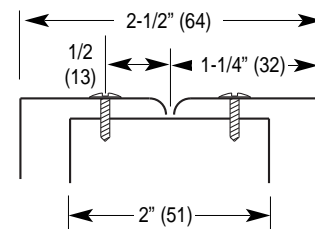

Multi-Panel In-Line Construction

Notes:

1. Maximum single panel width and height is 48" nominal size, regardless of blade alignment.
2. Panels are made in even inch increments unless specified otherwise.
3. Front blade alignment is as pictured.
4. Grille dimensions shown are nominal dimensions.
5. Panel flanges are sheared and aligned with joining strips.

- Height: 50-96"
- Width: Up to 48"
- Two Sections
- Any Blade Alignment

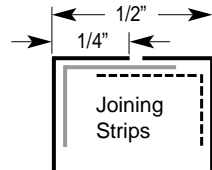
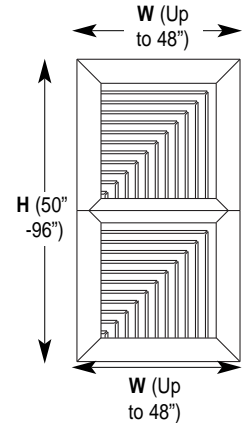

- Height: Over 96"
- Width: Up to 48"
- Three or more Sections
- Any Blade Alignment

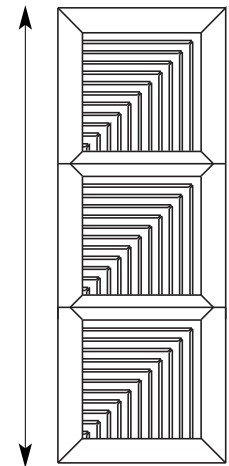

- Height: Up to 48"
- Width: 50" - 96"
- (Two Sections)
- Any Blade Alignment

- Height: Up to 48"
- Width: Over 96"
- Three or more Sections
- Any Blade Alignment

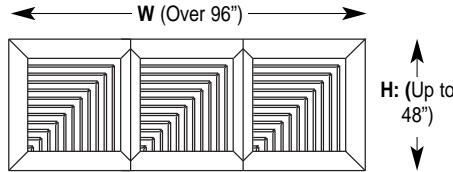
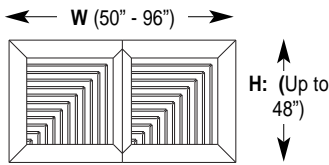

Multi-Panel Ganged Construction

Notes:

1. Maximum single panel width and height are 48" nominal size.
2. Panels are made in even inch increments unless specified otherwise.
3. Front blade alignment is always parallel to center support.
4. Either the vertical or horizontal joint can be sheared down, but not both.
5. The center support can be aligned vertically or horizontally, depending on blade alignment desired.
6. Grille dimensions shown are nominal dimensions.

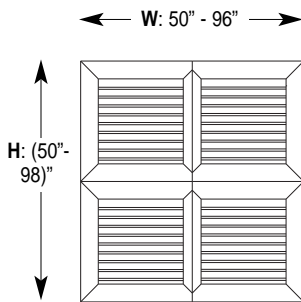

Cross-Sectional View of Center Support

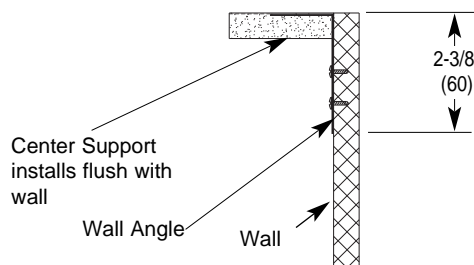
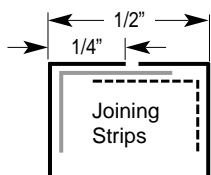
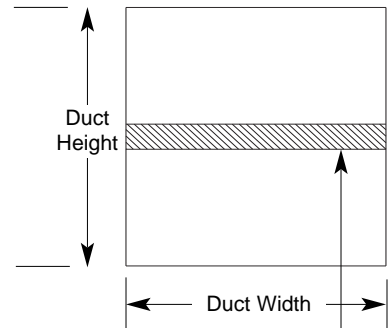
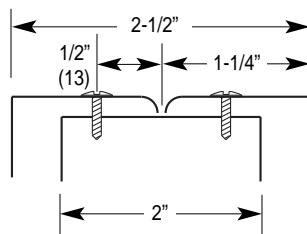

Center Support Mounted flush with wall (Shown aligned horizontally).

Sq. & Rect. Registers & Grilles

All Sections of Butted Grilles or Registers will be made in Listed Sizes as Standard.

STANDARD REGISTERS AND GRILLES

Applies to all models except louvered return air registers and grilles and door partition grilles.
Registers and grilles over 36" x 36" butting two or more grilles together.

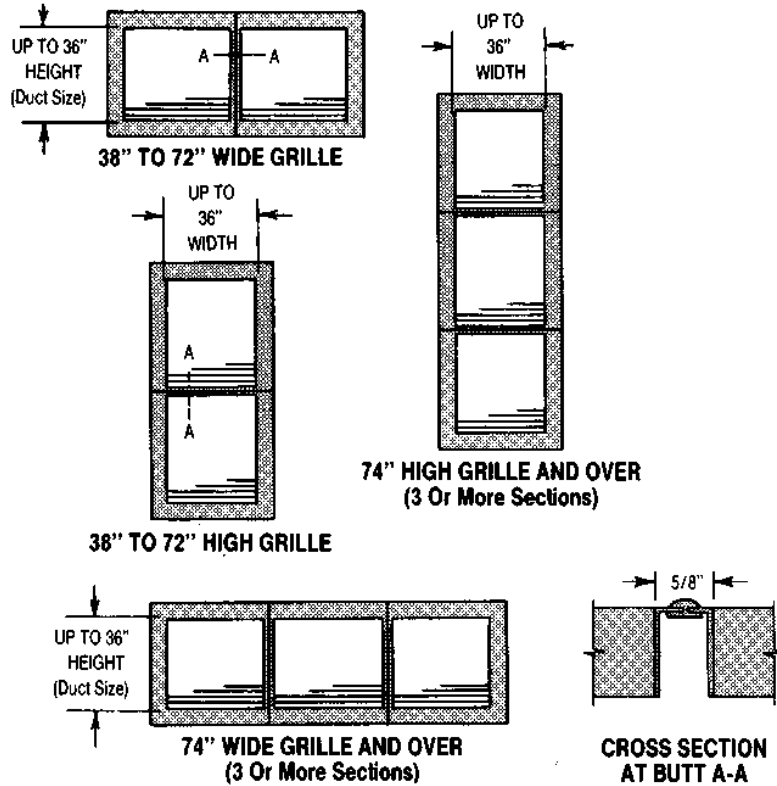

GRILLES AND REGISTERS HAVING FOUR SECTIONS AND OVER

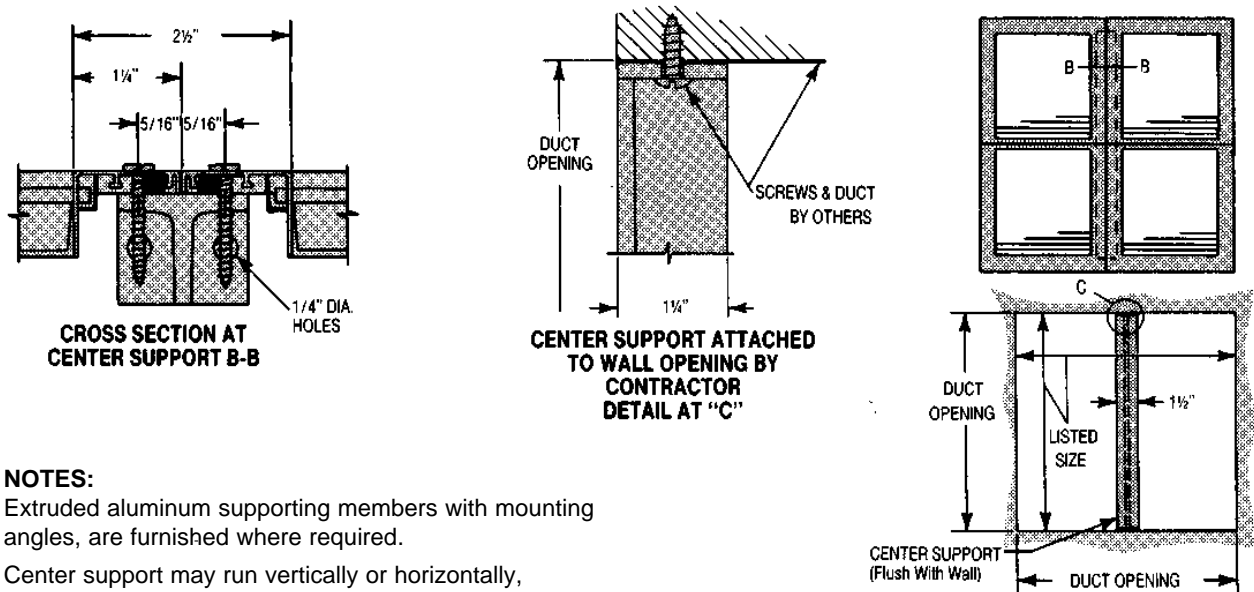

NOTES:

Extruded aluminum supporting members with mounting angles, are furnished where required.

Center support may run vertically or horizontally, depending upon combination of grilles used.

Combination of panels will be furnished to fit duct opening with satisfactory clearance.

Screw Hole Location for the following Registers & Grilles

	<u>Steel</u>	<u>Aluminum</u>	<u>Stainless Steel</u>
Single Deflection	RSSB, RTSB	RASM, RNSM	RLSB, RMSB, RKSB
Double Deflection	RSDB, RTDB	RADM, RNDM	RLDB, RMDB, RKDB
0° Fixed Return	RSRB, RTRB	RARM, RNRM	RLRB, RMRB, RKRB
45° Fixed Return	RSAB, RTAB	RAAM, RNAM	RLAB, RMAB, RKAB
Louvered Return	RSLA, RTLA	-----	-----
Perforated Return	RSFA, RTFA	RAFM, RNFM	-----

Notes:

- Screw holes on the face are standard on Registers and Grilles.
- Steel R&G can be ordered without screw holes, for use with concealed hangers (Opt. N).
- The screw holes is 5/32" in diameter.
- Each Register or Grille is provided with the appropriate number of screws as standard.
- The standard screw is #8 x 1-1/4" pan head screw, with a flat blade head.
- Tamper-proof screws are available as an option (Opt. B).

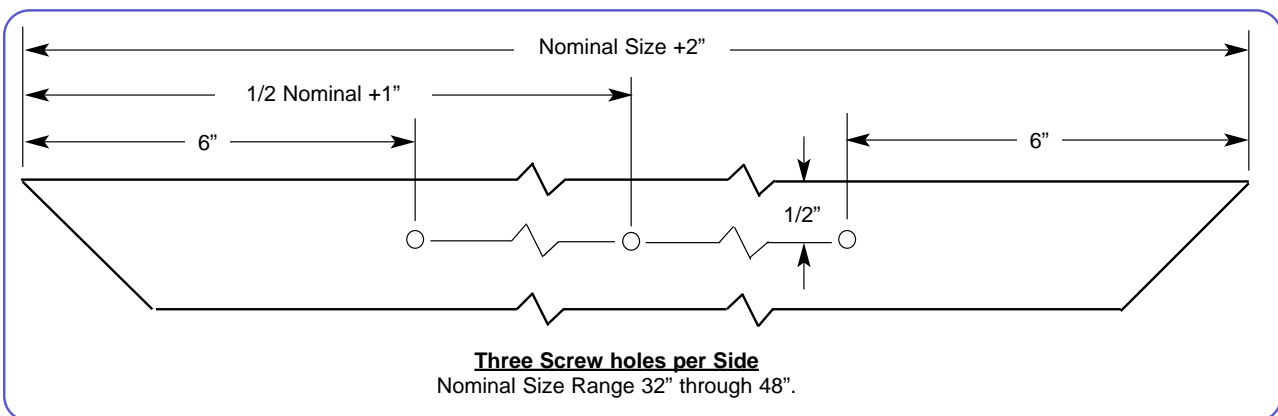
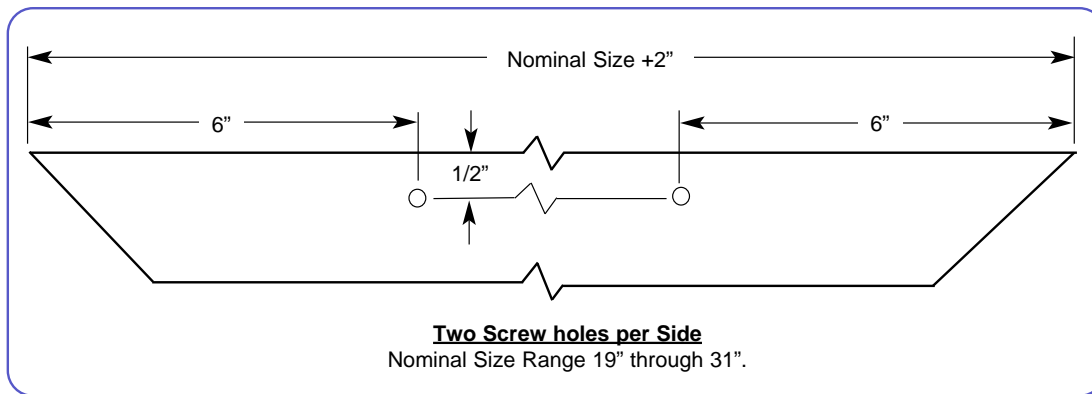
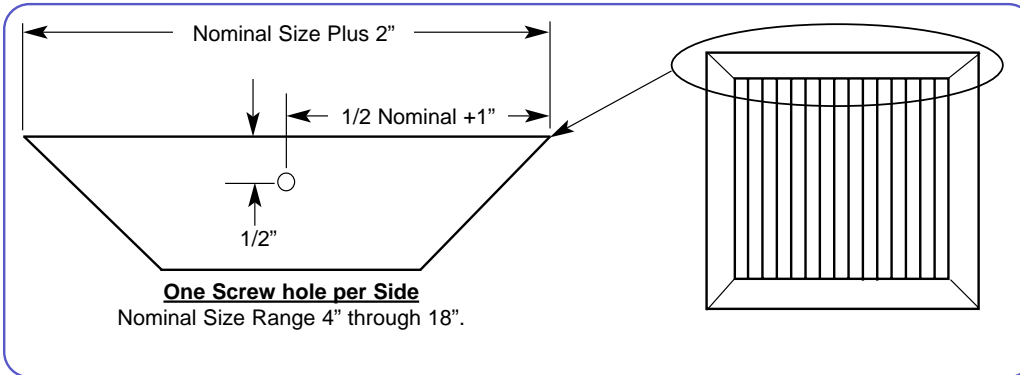

Sq. & Rect. Registers & Grilles