

Application:

Double Deflection Supply R&G provide a discharge directly away from the wall or ceiling with both vertically and horizontally.

Standard Features:

- Type 304 stainless steel construction.
- Blades are 3/4" deep, on 2/3" centers.
- Individually adjustable teardrop blades.
- Front blades can be aligned horizontally or vertically.
- Mounts in most wall or ceiling styles.
- Foam gasket around edge of frame.
- Register RKDB uses opposed blade damper RXTA (p. A437).
- Minimum panel size is 4" x 4".
- Maximum panel size is 36" x 36". Panels can be joined for larger sizes (p. A311).
- Standard finish is #22 satin polish with one coat of clear lacquer.

Optional Features:

- UL listed fusible link (p. A343).
- Tamper-proof screws (p. A342).
- Concealed hangers (p. A343).
- Pull cord and lever damper operators (p. A343).
- Debris screen (p.343).

Quick Select Chart

This shows grilles with:
 • A maximum NC of 35.
 • A minimum duct velocity of 300 FPM.

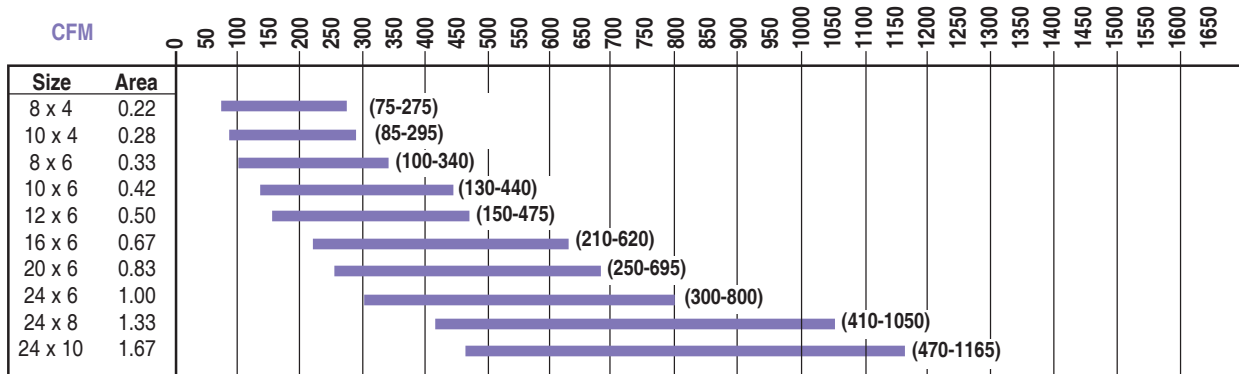

Model Numbering System

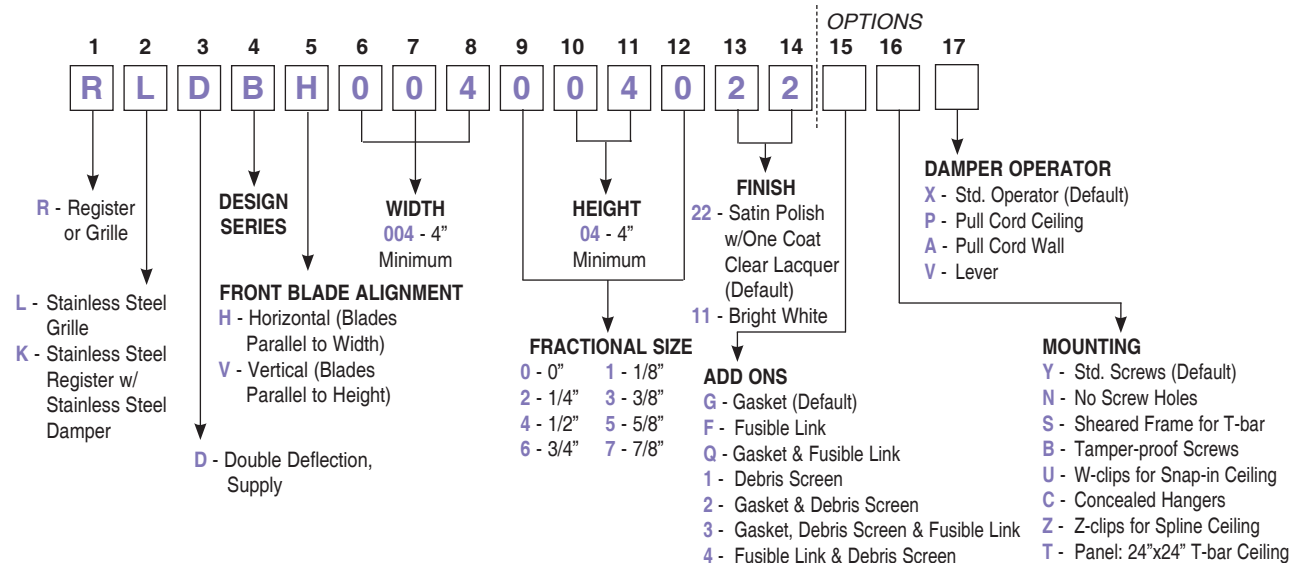

- Steel (RSDB, RTDB) • Stainless Steel (RLDB, RKDB)

Correction Factors for Grille Performance

• Total Pressure (P_t)

Use table data unchanged. For Total Pressure data encompassing all front and rear blade setting combinations, refer to this chart.

Blade Settings		Duct Velocity								
Front	Rear	300	400	500	600	700	800	900	1000	1200
0°	0°	0.011	0.020	0.030	0.043	0.059	0.076	0.096	0.120	0.170
	22-1/2°	0.015	0.026	0.040	0.058	0.079	0.105	0.130	0.160	0.230
	45°	0.032	0.055	0.085	0.120	0.165	0.220	0.280	0.340	0.490
22-1/2°	0°	0.016	0.028	0.043	0.062	0.084	0.110	0.140	0.170	0.240
	22-1/2°	0.019	0.033	0.051	0.074	0.099	0.130	0.160	0.200	0.285
	45°	0.034	0.059	0.091	0.130	0.175	0.230	0.295	0.360	0.510
45°	0°	0.034	0.059	0.088	0.125	0.170	0.215	0.270	0.330	0.460
	22-1/2°	0.036	0.063	0.095	0.135	0.185	0.235	0.295	0.360	0.510
	45°	0.047	0.082	0.125	0.175	0.230	0.330	0.370	0.455	0.650

• Throw

Use table data unchanged for 0° setting of the rear blades. **Multiply** the table data by the following factor for different rear blade angle settings.

Rear Blade Setting	22-1/2°	45°
Factor	0.89	0.60

• Sound Level

Use table data unchanged for 0° setting of the rear blades. **Add** the following to arrive at NC values for a 45° rear blade angle setting.

Duct Velocity (fpm)		300	400	500	600	700	800	900	1000	1200
Front	0°	10	10	10	9	9	9	8	8	8
Blade	22-1/2°	5	5	5	5	4	4	4	4	3
Setting	45°	3	3	3	3	2	2	2	2	2

Correction Factors for Register Performance

• Total Pressure (P_t)

Multiply the table data for Total Pressure data by the following factor for different blade angle setting combinations to arrive at Total Pressure for a register with a wide open damper.

		Rear Blade Setting		
		0°	22-1/2°	45°
Front	0°	1.70	1.50	1.10
Blade	22-1/2°	1.50	1.25	1.08
Setting	45°	1.20	1.10	1.06

• Throw

Use table data unchanged for 0° setting of the rear blades. **Multiply** the table data by the following factor for different rear blade angle settings.

Rear Blade Setting	22-1/2°	45°
Factor	0.89	0.60

• Sound Level

Use table data unchanged for 0° rear blade setting. **Add** the following to arrive at NC values for different rear blade angle settings.

Duct Velocity (fpm)		300	400	500	600	700	800	900	1000	1200
Rear	0°	0	0	0	0	0	0	0	0	0
Blade	22-1/2°	4	4	3	3	3	3	3	2	2
Setting	45°	7	7	6	6	6	6	6	5	5

Notes on Performance Data:

- Throw data is based on wall mounting height of 8-10 feet.
- Throw values are given in feet to a terminal velocity of 50 fpm.
- Testing was conducted under 20°ΔT cooling conditions.
- NC values are based on a room absorption of 10db re 10⁻¹² watts.
- Actual performance in the field may vary.

• Steel (RSDB, RTDB) • Stainless Steel (RLDB, RKDB)

		Duct Velocity	300	400	500	600	700	800	900	1000	1200
		Velocity Pressure	0.006	0.010	0.016	0.022	0.030	0.040	0.050	0.062	0.090
Nominal Size	Duct Area (ft ²)	Total 0°	0.011	0.020	0.030	0.043	0.059	0.076	0.096	0.120	0.170
		Press. 22-1/2°	0.016	0.028	0.043	0.062	0.084	0.110	0.140	0.170	0.240
		(Pt) 45°	0.034	0.059	0.088	0.125	0.170	0.215	0.270	0.330	0.460
6x6	0.25	Air Flow (CFM)	75	100	125	150	175	200	225	250	300
9x4	Front Blade Angle	Throw 0°	8	11	14	16	19	22	25	27	33
		22-1/2°	7	10	12	14	17	20	22	24	29
		45°	5	7	8	10	11	13	15	16	20
		Sound 0°	—	—	—	—	—	20	23	27	32
		22-1/2°	—	—	—	—	—	25	28	30	34
		45°	—	—	—	23	27	31	35	37	43
8x6	0.33	Air Flow (CFM)	100	135	170	200	235	270	305	335	405
12x4	Front Blade Angle	Throw 0°	9	12	16	19	23	25	29	31	38
		22-1/2°	8	11	14	17	20	23	25	28	34
		45°	6	8	9	11	14	15	17	19	23
		Sound 0°	—	—	—	—	—	22	25	29	34
		22-1/2°	—	—	—	20	24	27	30	32	36
		45°	—	—	—	25	29	33	37	39	45
10x6	0.42	Air Flow (CFM)	130	180	220	260	310	350	400	440	530
15x4 12x5	Front Blade Angle	Throw 0°	10	14	18	21	26	28	32	35	43
		22-1/2°	9	12	16	19	23	25	28	31	38
		45°	6	8	11	13	16	17	19	21	26
		Sound 0°	—	—	—	—	20	24	27	31	36
		22-1/2°	—	—	—	21	25	28	31	33	38
		45°	—	—	20	26	30	34	38	41	46
12x6	0.50	Air Flow (CFM)	150	200	250	300	350	400	450	500	595
9x8 18x4	Front Blade Angle	Throw 0°	11	15	19	22	27	30	34	37	46
		22-1/2°	10	13	17	20	24	27	30	33	41
		45°	7	9	11	14	17	18	20	22	28
		Sound 0°	—	—	—	—	21	25	28	32	37
		22-1/2°	—	—	—	22	26	29	32	34	39
		45°	—	—	21	26	31	35	39	42	47
14x6	0.58	Air Flow (CFM)	170	230	280	340	390	450	510	560	680
12x7 21x4	Front Blade Angle	Throw 0°	12	16	20	24	29	32	36	40	49
		22-1/2°	11	14	18	21	26	29	32	35	43
		45°	7	10	12	15	18	19	22	24	29
		Sound 0°	—	—	—	—	22	26	29	33	38
		22-1/2°	—	—	—	22	26	30	33	35	40
		45°	—	—	21	27	31	35	39	42	47
12x8	0.67	Air Flow (CFM)	210	280	350	400	480	550	620	690	830
16x6 24x4	Front Blade Angle	Throw 0°	14	18	22	26	31	35	40	44	54
		22-1/2°	12	16	20	23	28	31	36	39	48
		45°	8	11	13	16	19	21	24	26	32
		Sound 0°	—	—	—	—	23	27	30	34	39
		22-1/2°	—	—	—	23	27	31	34	36	41
		45°	—	—	22	27	32	36	40	43	48
18x6	0.75	Air Flow (CFM)	230	310	380	460	530	610	690	760	920
12x9 27x4	Front Blade Angle	Throw 0°	15	19	24	28	33	37	42	46	57
		22-1/2°	13	17	21	24	29	33	38	41	50
		45°	11	12	14	17	20	22	25	27	33
		Sound 0°	—	—	—	—	24	28	31	35	40
		22-1/2°	—	—	—	24	28	32	35	37	42
		45°	—	—	22	28	32	36	40	44	49
12x10	0.83	Air Flow (CFM)	250	330	420	500	580	670	750	830	1000
30x4 20x6 15x8	Front Blade Angle	Throw 0°	15	20	25	29	34	39	44	48	59
		22-1/2°	13	17	22	25	30	34	39	42	52
		45°	9	12	15	18	21	24	27	29	34
		Sound 0°	—	—	—	20	25	29	32	35	41
		22-1/2°	—	—	—	24	28	32	35	38	43
		45°	—	—	23	28	32	37	41	44	49

Notes on Performance Data:

- Throw data is based on wall mounting height of 8-10 feet.
- Throw values are given in feet to a terminal velocity of 50 fpm.
- Testing was conducted under 20°ΔT cooling conditions.
- Actual performance in the field may vary.
- Sound values are given in NC and are based on a room absorption of 10db re 10⁻¹² watts.

• Steel (RSDB, RTDB) • Stainless Steel (RLDB, RKDB)

		Duct Velocity	300	400	500	600	700	800	900	1000	1200
		Velocity Pressure	0.006	0.010	0.016	0.022	0.030	0.040	0.050	0.062	0.090
Nominal Size	Duct Area (ft ²)	Total 0°	0.011	0.020	0.030	0.043	0.059	0.076	0.096	0.120	0.170
		Press. 22-1/2°	0.016	0.028	0.043	0.062	0.084	0.110	0.140	0.170	0.240
		(Pt) 45°	0.034	0.059	0.088	0.125	0.170	0.215	0.270	0.330	0.460
12x12	1.00	Air Flow (CFM)	300	400	500	600	700	800	900	1000	1200
16x9 18x8 24x6	Front Blade Angle	Throw 0°	16	21	27	31	36	43	48	52	63
		22-1/2°	14	19	24	28	32	38	43	46	56
		45°	10	13	16	19	22	26	29	31	38
		Sound 0°	—	—	—	21	26	30	33	36	42
		22-1/2°	—	—	20	25	29	33	36	39	44
		45°	—	—	23	29	33	37	41	45	50
14x14	1.36	Air Flow (CFM)	410	540	680	820	950	1090	1220	1360	1630
49x4 28x7	Front Blade Angle	Throw 0°	18	24	31	36	43	49	55	60	74
		22-1/2°	16	21	28	32	38	44	49	53	66
		45°	11	14	19	22	26	29	33	36	44
		Sound 0°	—	—	—	23	27	31	35	38	43
		22-1/2°	—	—	21	26	30	34	37	40	45
		45°	—	—	24	30	35	39	43	46	52
18x12	1.50	Air Flow (CFM)	470	620	780	930	1090	1240	1400	1560	1870
36x6 54x4 24x9 27x8	Front Blade Angle	Throw 0°	19	26	33	39	46	52	58	65	78
		22-1/2°	17	23	29	34	41	46	52	57	69
		45°	12	15	20	24	27	31	35	39	46
		Sound 0°	—	—	—	24	28	32	36	39	44
		22-1/2°	—	—	21	26	31	35	38	41	46
		45°	—	—	24	30	35	39	43	46	52
16x16	1.77	Air Flow (CFM)	530	710	890	1070	1250	1420	1600	1780	2100
32x8 64x4	Front Blade Angle	Throw 0°	21	28	35	43	49	55	62	70	82
		22-1/2°	19	25	31	38	44	49	55	62	73
		45°	13	17	21	26	29	33	37	42	49
		Sound 0°	—	—	—	25	30	34	37	40	46
		22-1/2°	—	—	22	27	32	36	39	42	47
		45°	—	—	25	31	36	40	44	47	53
18x16	2.00	Air Flow (CFM)	600	800	1000	1200	1400	1600	1800	2000	2400
24x12 48x6 36x8 32x9	Front Blade Angle	Throw 0°	22	29	37	45	52	58	65	72	86
		22-1/2°	20	26	33	40	47	52	58	65	78
		45°	13	18	22	27	31	35	39	44	52
		Sound 0°	—	—	20	25	30	34	38	41	46
		22-1/2°	—	—	22	28	32	36	39	43	48
		45°	—	—	25	31	36	40	44	47	53
18x18	2.25	Air Flow (CFM)	680	900	1120	1350	1580	1800	2000	2200	2700
54x6 27x12 36x9	Front Blade Angle	Throw 0°	24	31	40	47	56	62	70	76	93
		22-1/2°	21	28	36	42	50	55	62	68	93
		45°	14	19	24	28	34	37	42	46	56
		Sound 0°	—	—	21	26	31	35	39	42	47
		22-1/2°	—	—	23	29	33	37	40	44	49
		45°	—	—	26	32	37	41	45	48	54
20x20	2.78	Air Flow (CFM)	830	1110	1390	1670	1950	2200	2500	2800	3330
22x18 40x10 25x16	Front Blade Angle	Throw 0°	26	34	44	52	61	70	78	88	103
		22-1/2°	23	30	39	46	54	62	69	78	92
		45°	16	21	26	31	37	42	47	53	62
		Sound 0°	—	—	23	28	33	37	40	43	49
		22-1/2°	—	—	24	30	35	38	42	45	50
		45°	—	—	26	32	37	42	46	49	55
36x12	3.00	Air Flow (CFM)	900	1200	1500	1800	2100	2400	2700	3000	3600
27x16 54x9	Front Blade Angle	Throw 0°	27	36	46	54	63	73	81	91	109
		22-1/2°	24	32	41	48	57	65	72	81	99
		45°	16	22	27	32	38	44	49	55	65
		Sound 0°	—	—	23	28	33	37	41	43	51
		22-1/2°	—	—	24	30	35	39	42	45	51
		45°	—	—	26	32	37	42	46	49	55

Notes on Performance Data:

- Throw data is based on wall mounting height of 8-10 feet.
- Throw values are given in feet to a terminal velocity of 50 fpm.
- Testing was conducted under 20°ΔT cooling conditions.
- Actual performance in the field may vary.
- Sound values are given in NC and are based on a room absorption of 10db re 10⁻¹² watts.

• Steel (RSDB, RTDB) • Stainless Steel (RLDB, RKDB)

		Duct Velocity	300	400	500	600	700	800	900	1000	1200
		Velocity Pressure	0.006	0.010	0.016	0.022	0.030	0.040	0.050	0.062	0.090
Nominal Size	Duct Area (ft ²)	Total 0°	0.011	0.020	0.030	0.043	0.059	0.076	0.096	0.120	0.170
		Press. 22-1/2°	0.016	0.028	0.043	0.062	0.084	0.110	0.140	0.170	0.240
		(Pt) 45°	0.034	0.059	0.088	0.125	0.170	0.215	0.270	0.330	0.460
22x22	3.36	Air Flow (CFM)	1010	1340	1680	2000	2400	2700	3000	3400	
30x16 40x12 32x15	Front Blade Angle	Throw 0°	28	39	48	57	67	76	85	95	
		22-1/2°	25	35	43	51	60	68	76	85	
		45°	17	23	29	34	40	46	51	57	
		Sound 0°	—	—	24	29	34	38	42	44	
		22-1/2°	—	—	25	30	36	40	43	46	
		45°	—	—	27	33	38	43	47	50	
24x24	4.00	Air Flow (CFM)	1200	1600	2000	2400	2800	3200	3600		
48x12 64x9 18x32	Front Blade Angle	Throw 0°	31	41	52	62	72	83	93		
		22-1/2°	28	36	46	55	64	74	83		
		45°	19	25	31	37	43	50	56		
		Sound 0°	—	—	25	30	35	39	43		
		22-1/2°	—	—	26	31	36	40	44		
		45°	—	—	27	34	39	44	48		
26x26	4.69	Air Flow (CFM)	1400	1880	2300	2800	3300	3800	4200		
48x14 28x24 32x21 42x16	Front Blade Angle	Throw 0°	34	45	55	66	79	90	101		
		22-1/2°	30	40	50	59	70	80	90		
		45°	20	27	33	40	47	54	61		
		Sound 0°	—	—	26	31	36	40	44		
		22-1/2°	—	—	27	32	37	41	45		
		45°	—	20	29	35	40	45	49		
28x28	5.44	Air Flow (CFM)	1630	2200	2700	3300	3800	4400			
49x16 30x26 39x20 60x13	Front Blade Angle	Throw 0°	35	48	59	74	83	97			
		22-1/2°	31	43	53	66	74	86			
		45°	21	29	35	44	50	58			
		Sound 0°	—	—	27	32	37	41			
		22-1/2°	—	20	27	33	38	42			
		45°	—	20	29	35	40	45			
30x30	6.25	Air Flow (CFM)	1880	2500	3100	3700	4400	5000			
54x25 90x10 75x12 45x20	Front Blade Angle	Throw 0°	38	51	63	76	90	103			
		22-1/2°	34	45	56	68	80	92			
		45°	23	31	38	46	54	62			
		Sound 0°	—	—	28	33	38	42			
		22-1/2°	—	20	28	33	39	43			
		45°	—	20	29	35	41	46			
42x24	7.00	Air Flow (CFM)	2100	2800	3600	4200	5000	5700			
56x18 48x21 84x12 36x28	Front Blade Angle	Throw 0°	41	54	70	80	96	99			
		22-1/2°	36	48	62	71	85	98			
		45°	25	32	42	48	58	68			
		Sound 0°	—	—	28	34	39	43			
		22-1/2°	—	21	28	34	39	44			
		45°	—	21	29	36	41	47			
48x24	8.00	Air Flow (CFM)	2400	3200	5000	4800	5600				
36x32 72x16 64x18	Front Blade Angle	Throw 0°	44	58	72	88	102				
		22-1/2°	39	52	64	78	91				
		45°	26	35	43	53	61				
		Sound 0°	—	20	29	34	40				
		22-1/2°	—	22	29	34	40				
		45°	—	22	30	36	42				
36x36	9.00	Air Flow (CFM)	2700	3600	4500	5400					
72x18 54x24	Front Blade Angle	Throw 0°	46	61	76	91					
		22-1/2°	41	54	68	81					
		45°	28	37	46	55					
		Sound 0°	—	20	29	35					
		22-1/2°	—	22	29	35					
		45°	—	22	30	37					

Notes on Performance Data:

- Throw data is based on wall mounting height of 8-10 feet.
- Throw values are given in feet to a terminal velocity of 50 fpm.
- Testing was conducted under 20°ΔT cooling conditions.
- Actual performance in the field may vary.
- Sound values are given in NC and are based on a room absorption of 10db re 10⁻¹² watts.

Multi-Panel Construction for the following Registers & Grilles

	Steel	Stainless Steel	Aluminum
Single Deflection	RSSB, RTSB	RLSB, RKSB	RASM, RNSM
Double Deflection	RSDB, RTDB	RLDB, RKDB	RADM, RNDM
0° Fixed Return	RSRB, RTRB	RLRB, RKRB	RARM, RNRM
45° Fixed Return	RSAB, RTAB	RLAB, RKAB	RAAM, RNAM

In-line Construction

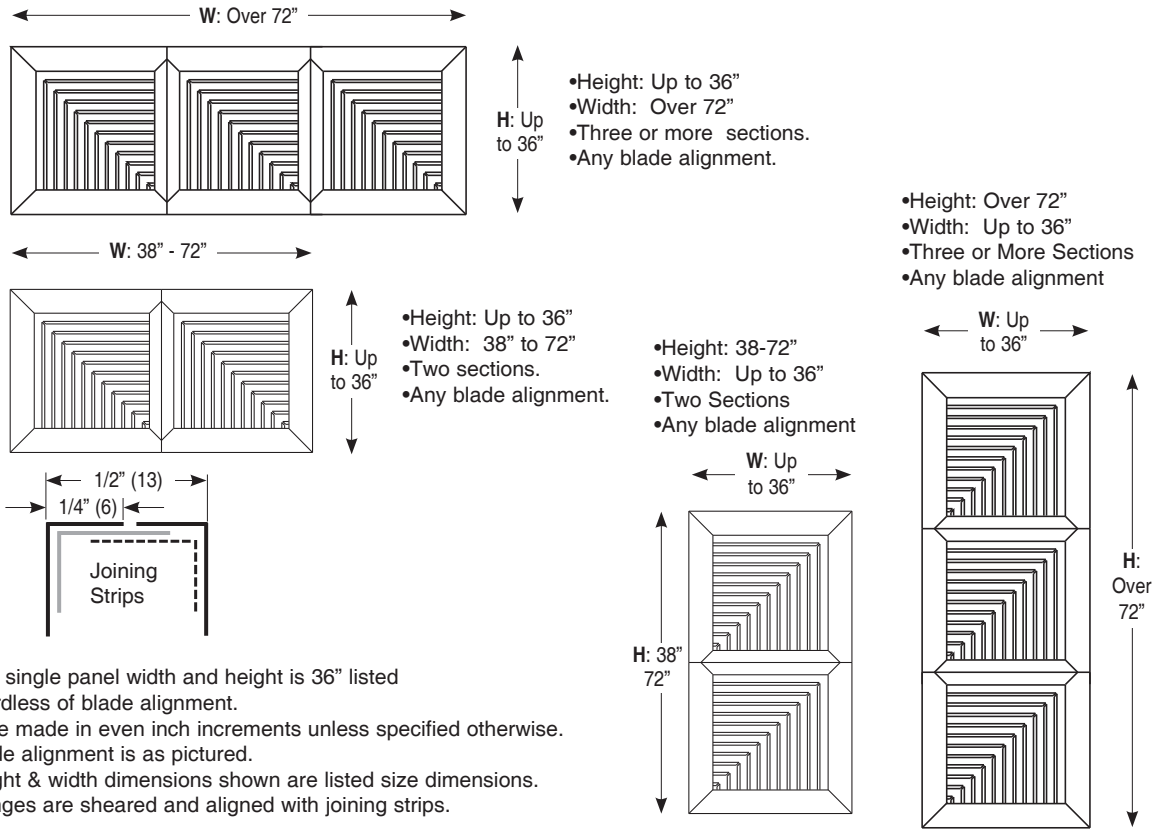

Notes:

1. Maximum single panel width and height is 36" listed size regardless of blade alignment.
2. Panels are made in even inch increments unless specified otherwise.
3. Front blade alignment is as pictured.
4. Grille height & width dimensions shown are listed size dimensions.
5. Panel flanges are sheared and aligned with joining strips.

Ganged Construction

Notes:

1. Maximum single panel width is 36" listed size.
2. Maximum single panel height is 36" listed size.
3. Panels will be made in even inch increments unless specified otherwise.
4. Front blade alignment is always parallel to center support.
5. Either the vertical or horizontal joint can be sheared down, but not both.
6. The center support can be aligned vertically or horizontally, depending on blade alignment desired. It is shown here mounted horizontally.
7. Grille height and width dimensions shown are listed size dimensions.
8. Metric dimensions are shown in millimeters.

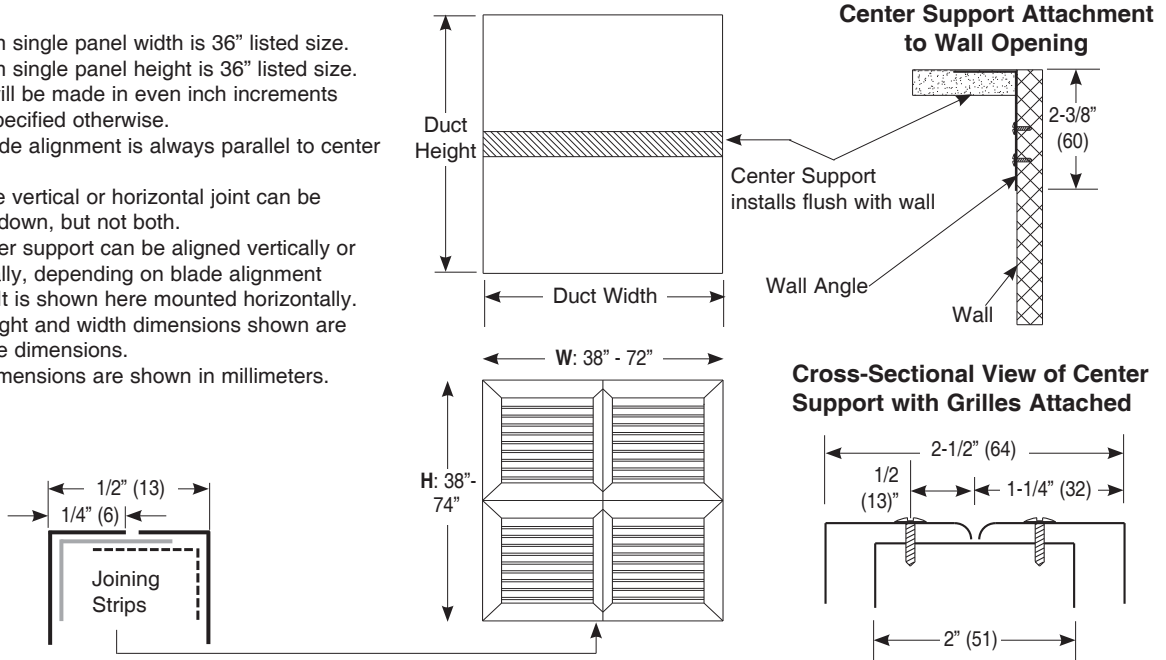

Multi-Panel Construction for the following Registers & Grilles

Steel
 Louvered Return RSLA, RTLA
 Perforated Return RSFA, RTFA

In-Line Construction

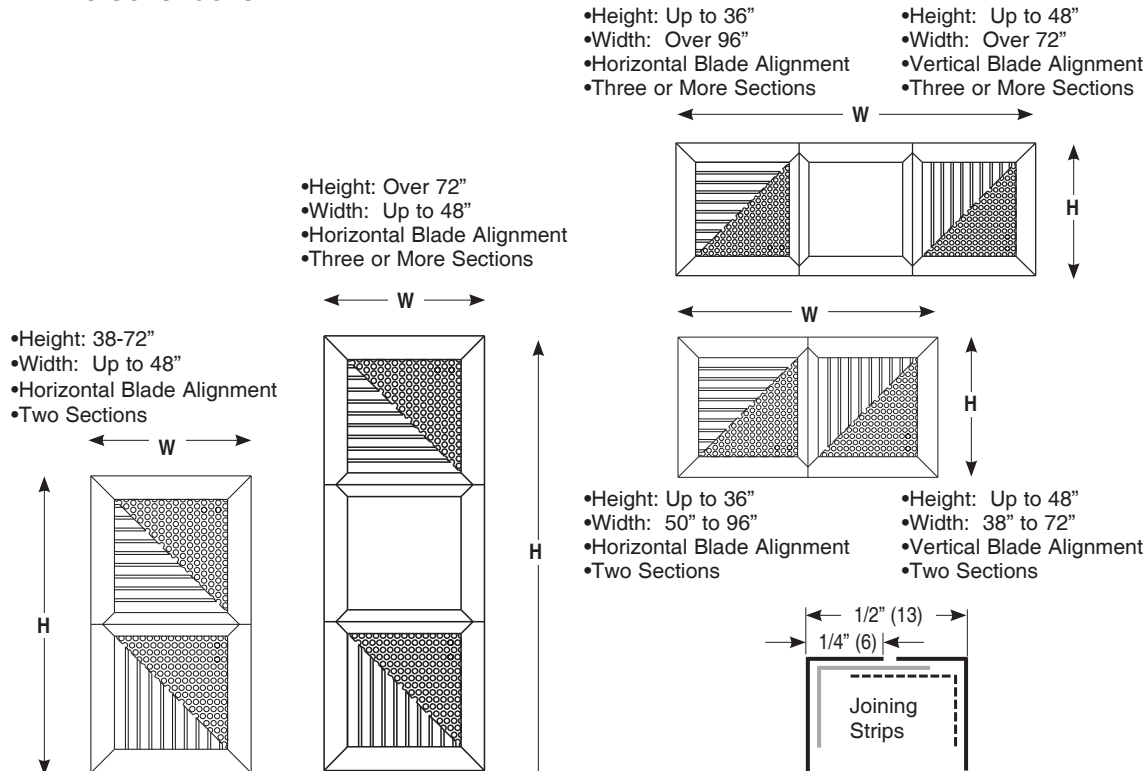

Notes:

1. Panels will be made in even inch increments unless specified otherwise.
2. Dimensions shown are listed size dimensions.
3. Max. blade length on louvered face models is nominal 48".
4. Panels are sheared and aligned with joining strips.

Ganged Construction

Notes:

1. Either the vertical or horizontal joint can be sheared down, but not both.
2. Maximum single panel width is 48" listed size.
3. Maximum blade length on louvered face models is listed size 48".
4. Maximum single panel height is 36" listed size.
5. Panels are made in even inch increments unless specified otherwise.
6. Blade alignment is always parallel to center support.
7. The center support can be aligned vertically or horizontally, depending on the blade alignment desired. It is shown here mounted horizontally.
8. Grille dimensions shown are listed size dimensions.

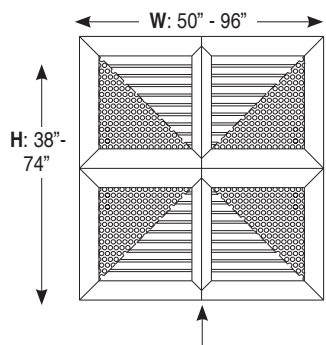
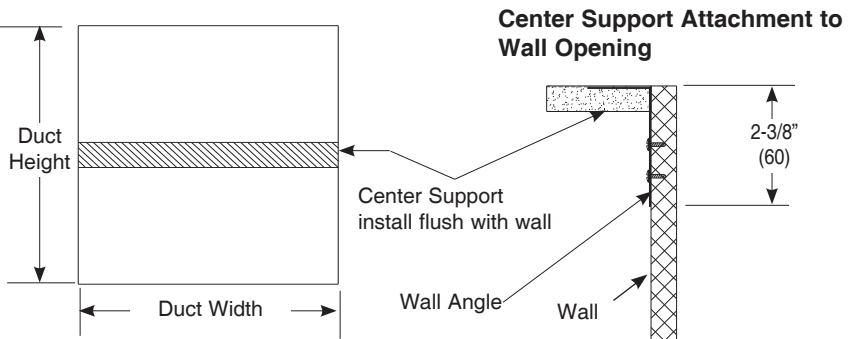
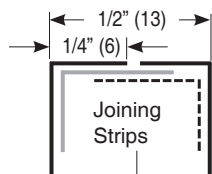

Cross-Sectional View of Center Support with Grilles Attached

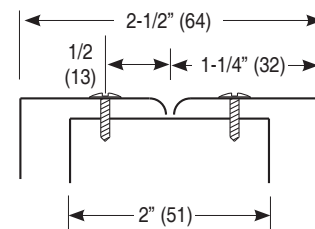

Multi-Panel In-Line Construction

Notes:

1. Maximum single panel width and height is 48" nominal size, regardless of blade alignment.
2. Panels are made in even inch increments unless specified otherwise.
3. Front blade alignment is as pictured.
4. Grille dimensions shown are nominal dimensions.
5. Panel flanges are sheared and aligned with joining strips.

- Height: 50-96"
- Width: Up to 48"
- Two Sections
- Any Blade Alignment

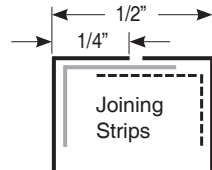
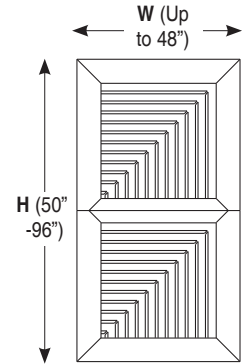

- Height: Over 96"
- Width: Up to 48"
- Three or more Sections
- Any Blade Alignment

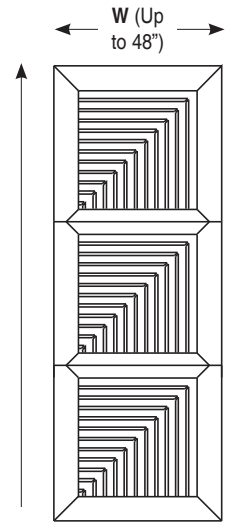

- Height: Up to 48"
- Width: 50" - 96"
- Two Sections
- Any Blade Alignment

- Height: Up to 48"
- Width: Over 96"
- Three or more Sections
- Any Blade Alignment

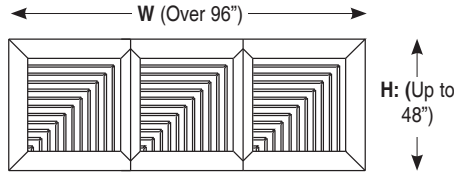
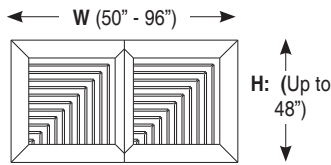

Multi-Panel Ganged Construction

Notes:

1. Maximum single panel width and height are 48" nominal size.
2. Panels are made in even inch increments unless specified otherwise.
3. Front blade alignment is always parallel to center support.
4. Either the vertical or horizontal joint can be sheared down, but not both.
5. The center support can be aligned vertically or horizontally, depending on blade alignment desired.
6. Grille dimensions shown are nominal dimensions.

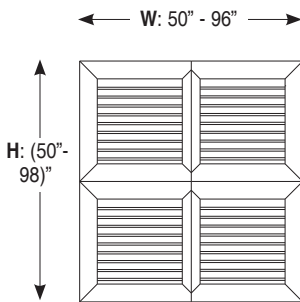

Cross-Sectional View of Center Support

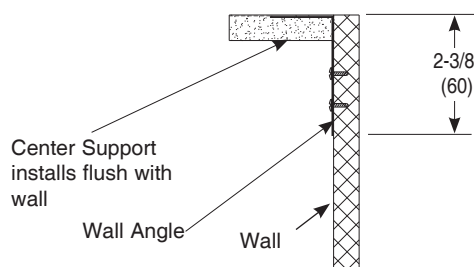
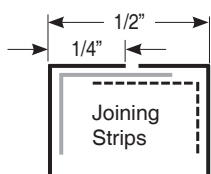
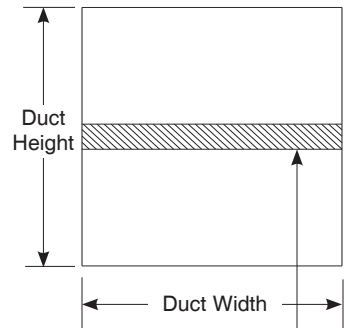
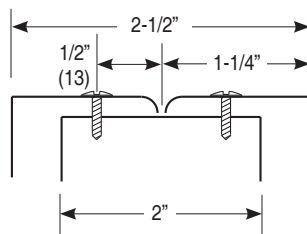

Center Support Mounted flush with wall (Shown aligned horizontally).

All Sections of Butted Grilles or Registers will be made in Listed Sizes as Standard.

STANDARD REGISTERS AND GRILLES

Applies to all models except louvered return air registers and grilles and door partition grilles.
Registers and grilles over 36" x 36" butting two or more grilles together.

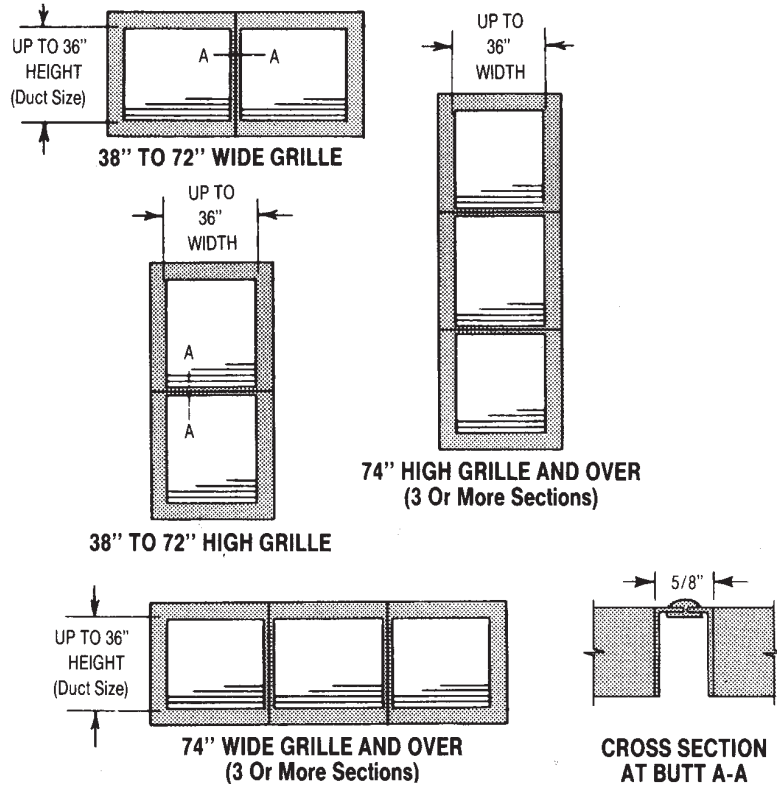

GRILLES AND REGISTERS HAVING FOUR SECTIONS AND OVER

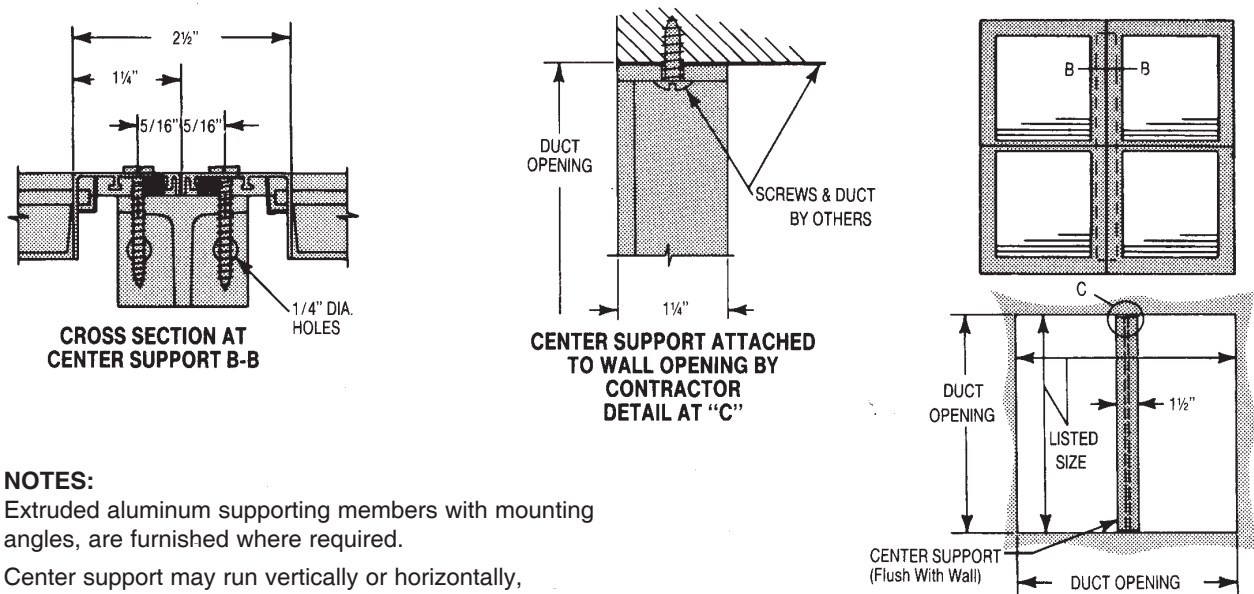

NOTES:

Extruded aluminum supporting members with mounting angles, are furnished where required.

Center support may run vertically or horizontally, depending upon combination of grilles used.

Combination of panels will be furnished to fit duct opening with satisfactory clearance.

Screw Hole Location for the following Registers & Grilles

	Steel	Aluminum	Stainless Steel
Single Deflection	RSSB, RTSB	RASM, RNSM	RLSB, RKSB
Double Deflection	RSDB, RTDB	RADM, RNDM	RLDB, RKDB
0° Fixed Return	RSRB, RTRB	RARM, RNRM	RLRB, RKRB
45° Fixed Return	RSAB, RTAB	RAAM, RNAM	RLAB, RKAB
Louvered Return	RSLA, RTLA	-----	-----
Perforated Return	RSFA, RTFA	RAFM, RNFM	-----

Notes:

- Screw holes on the face are standard on Registers and Grilles.
- Steel R&G can be ordered without screw holes, for use with concealed hangers (Opt. N).
- The screw holes is 5/32" in diameter.
- Each Register or Grille is provided with the appropriate number of screws as standard.
- The standard screw is #8 x 1-1/4" pan head screw, with a flat blade head.
- Tamper-proof screws are available as an option (Opt. B).

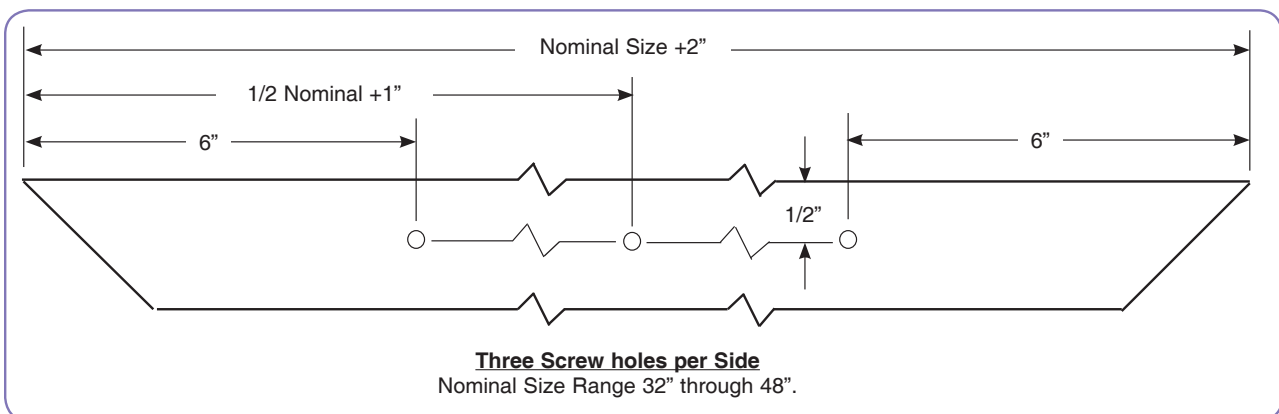
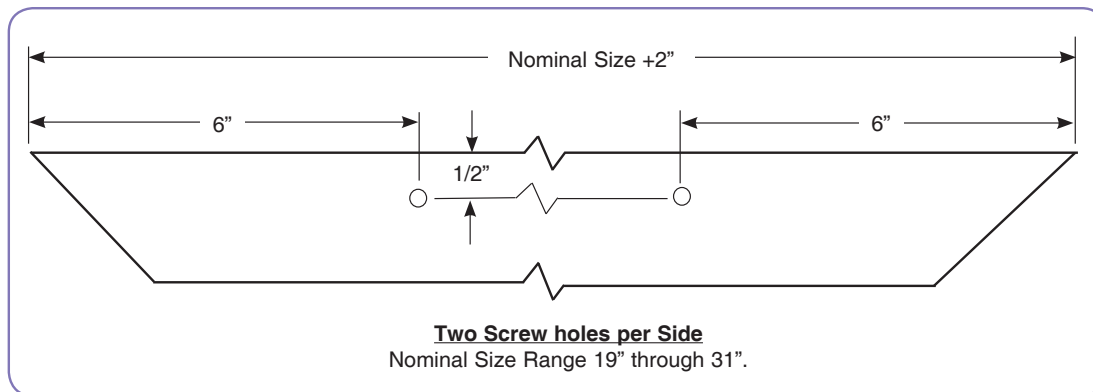
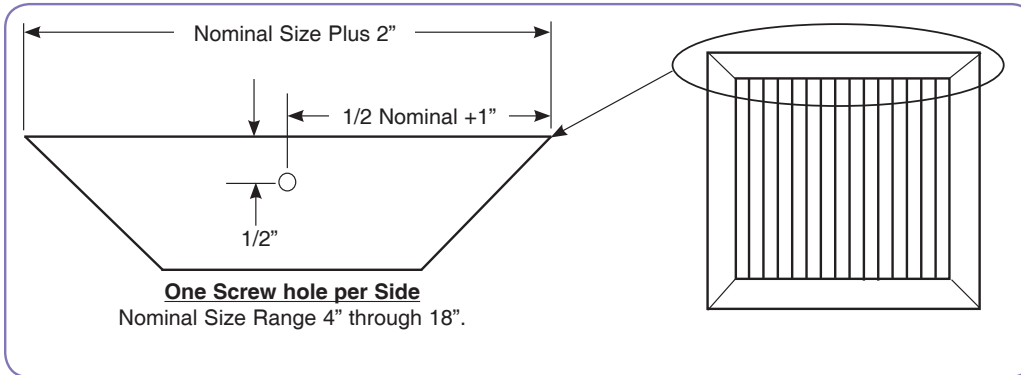

Sq. & Rect. Registers & Grilles