

# AIR SPECIALTIES *express*®

Commercial HVAC Products

## AIR DISTRIBUTION PRODUCTS: *Diffusers, Registers, Grilles and Air Terminal Units*

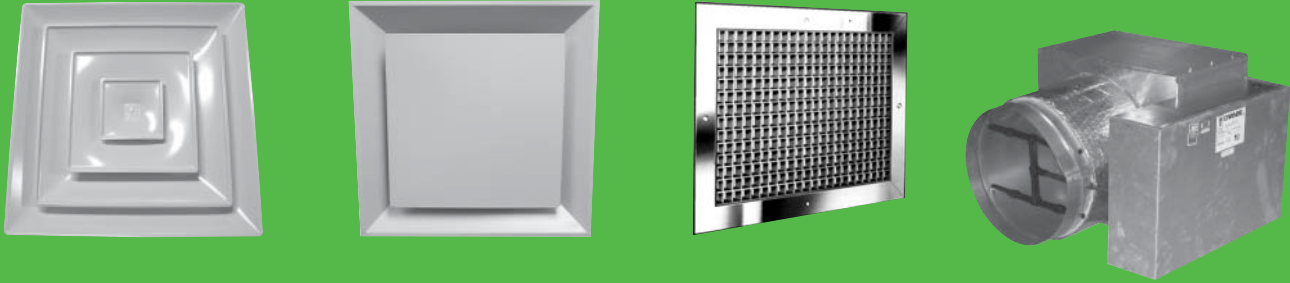

## AIR MOVEMENT PRODUCTS: *Centrifugal Ventilators, Axial Fans and Non-Powered Ventilation*



## AIR CONDITIONING PRODUCTS: *Humidifiers, Energy Recovery Ventilators, Core Ventilators and Mini-Systems*



Catalog ASX-CG-09S  
September 2016



Verona, WI 53593 • Phone: 877/945-9175 • Fax: 608/845-6504  
www.airspecialties.com • info@airspecialties.com

## A Fast Ship Program For Every Need.

ASX offers many stock and quick build programs to meet your needs for fast shipment even on custom configured products. ASX sales representatives lead the industry with online factory order capability, electronically expediting your order directly into the factory production stream.

**PLEASE NOTE: LEAD TIMES ARE BASED ON ACKNOWLEDGMENT DATE AND NOT NECESSARILY FROM THE ORDER DATE.**

**48  
Hour**

### 48-Hour Stock Service

■ A Large selection of products with off-the-shelf shipment within 48 Hours.

- Steel Square Diffusers
- Steel Louvered Diffusers
- Aluminum Registers & Grilles
- Humidifier Accessories
- Steel Stamped Perforated Diffusers
- Aluminum Square Diffusers
- Equalizing Grids
- Steel Registers & Grilles
- Dampers - Round & Square
- Ceiling Fans & Accessories

**EQS**

### Diffuser, Register & Grille Emergency Quick Ship

- Stamped Louvered Diffusers
- Stamped Perforated Diffusers
- Square & Rectangular Diffusers
- Linear Diffusers
- Spun Round Diffusers
- Registers & Grilles
- Auxiliary Frames
- Slot Diffusers
- Egg Crate

**7  
Day**

**10  
Day**

**Vent  
Express**

### Ventilator Express Service

**2  
Day**

**5  
Day**

**10  
Day**

■ Express service on hundreds of ventilators.  
■ All express power vents have motor and drive mounted.

- Centrifugal Power Roof Ventilators
- Square In-line Duct Fans
- Centrifugal Wall Ventilators
- UL-762 Restaurant Exhausters
- Sidewall Propeller Fans
- Centrifugal Filtered Supply Fans
- Ceiling & Cabinet Fans
- Gravity Intake/Exhaust Hoods
- Curb Adaptors Only, Dampers & Accessories

**VAV  
Quickship**

### Terminal Unit Fast Ship Service

**5  
Day**

**10  
Day**

■ Fast shipment of most popular unit types and a large selection of unit sizes.

- Single Duct With or Without Hot Water Reheat
- Pressure Dependent Controls
- Pressure Independent Controls
- Accessories

**Louver/  
Damper  
Fast Ship**

### Louver and Damper Fast Ship Service

**6  
Day**

**10  
Day**

■ Fast shipment of all louver and damper models.

**Fire  
Damper  
Fast Ship**

- Louvers
- Dampers
- Penthouses
- Fire and Smoke Dampers

# Table of Contents

## Air Distribution Products

Diffusers.....	4
Registers and Grilles .....	8
VAV Terminal Units .....	10

## Air Movement Products

Fans and Ventilators.....	12
Louvers and Penthouses.....	18
Dampers .....	18

## Air Conditioning Products

Energy Recovery Products.....	20
Humidifiers.....	21

---

## Software for Equipment Selection and Reference

Carnes Complete Selection Software is a web application. Go to <https://webapp.carnes.com> where you can set up as a guest account to select our products.

### **FAN-C-LECT™**

The easy to use software program for the selection of power roof ventilators, propeller fans and ceiling fans. The program will generate performance and BHP curves and dimensional drawings.

### **VAV-C-LECT™**

This terminal unit selection program selects throttling and fan powered terminal units complete with integrated water and electric coil performance data. Equipment selection and performance data is presented in a user defined page format.

### **ER-C-LECT™**

The energy recovery selection program enables quick and simple selections of Energy Recovery, Energy Recovery Ventilators, Core Ventilators and Energy MiniSystems with or without heating and/or cooling coil(s). Complete submittal information is generated for each selection.

### **HUMIDIFIER-C-LECT™**

Humidifier load calculations using the programs are extremely easy by simply entering design conditions or room dimensions. The humidification load is calculated and the program then leads the user through a step-by-step selection of the appropriate humidifier.

*All Carnes selection software supports IP and SI (metric) units of measure.*

## Air Distribution Products

48  
Hour

EQS

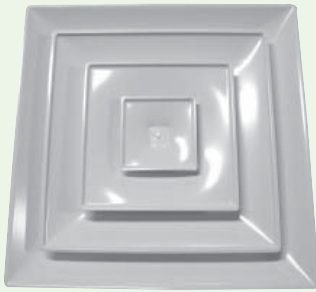

Model SFTB

### STAMPED LOUVERED DIFFUSERS

ASX round neck square diffusers combine the unobtrusive appearance of square diffusers with optimum performance of round diffusers. The smooth lines created by stamping process eliminates the miter lines and creates a modern, aesthetically pleasing diffuser. Models available for fixed horizontal or adjustable horizontal or vertical air patterns. Models also available with solid metal plaque face. Round necks are standard and designed primarily for flex duct connection. Collar height is a full 1-1/4" for easy connection taping. Round neck diffusers are available in eight sizes and can be selected for either surface mounting or T-bar lay-in. Models are available in cold roll steel or aluminum construction.

### PLAQUE DIFFUSER

This offers an architecturally pleasing alternative to the standard stamped louvered diffuser. The flat surface of the plaque face blends better with suspended ceiling tiles, and the design delivers horizontal flow at low air flows, making it very well suited for VAV system designs. Round neck duct connections make this easy to install with flex duct.

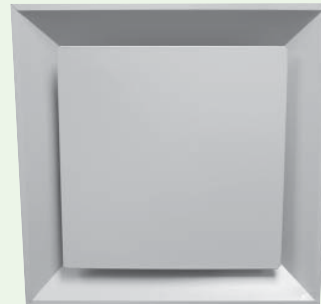

48  
Hour

EQS

Model SFPA

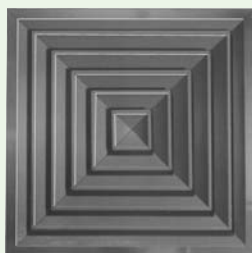

Model SAFM

### EXTRUDED ALUMINUM DIFFUSERS

Extruded aluminum square and rectangular ceiling diffusers feature all-aluminum construction giving the unit a sharp, clean appearance. The diffusers are available in 1-way, 2-way, 2-way corner, 3-way and 4-way patterns. Great flexibility with three different frame styles. The ceiling diffusers are available with square, rectangular or round necks.

### SQUARE LOUVERED/PLAQUE DIFFUSER

This offers an architecturally pleasing alternative to the standard diffuser. The flat surface of the plaque face blends better with suspended ceiling tiles, and the louvered design around the perimeter delivers horizontal flow at low air flows, making it very well suited for VAV systems designs. It is available in a range of inlet sizes, and from 1 to 4 slots, so as to accommodate a range of air flows. It is designed to lay into 24" x 24" T-bar ceilings, and round neck duct connections make this easy to install with flex duct.

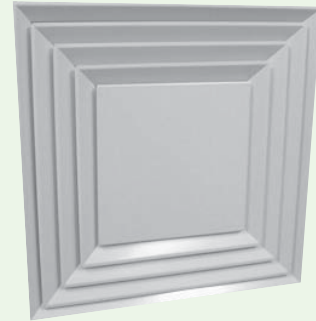

Model SKPB

48  
Hour

EQS

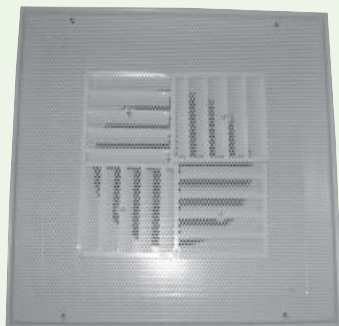

Model SPAB

### STAMPED PERFORATED DIFFUSERS ROUND AND SQUARE NECK

ASX stamped perforated diffusers are available with round or square inlets. By simple on-the-job adjustment, 1-way, 2-way, 2-way corner, 3-way or 4-way air patterns can be attained. Matching supply and return models are available for plaster, T-bar, Fineline® or spline ceilings. Round neck models are available in sizes 5" to 16" and square neck models in sizes 6 x 6 to 22 x 22. Models are also available with adjustable curved vane pattern controls. These models are available in 1-way, 2-way, 2-way corner, 3-way or 4-way air patterns with round or square inlets. Models are available in cold roll steel or aluminum construction.

### FABRICATED SQUARE AND RECTANGULAR DIFFUSERS

These square and rectangular diffusers are available in 1-way, 2-way, 2-way corner, 3-way and 4-way blow patterns. Four frame styles provide design flexibility. Adjustable models are available that provide horizontal, vertical or intermediate patterns. Models are available in steel or formed aluminum construction.



48  
Hour

EQS

Model SKSA

10  
Day

EQS



Model SMFB

### MODULAR CORE DIFFUSER

ASX SM Series modular core diffusers are extremely versatile and will meet most job applications. Models are available in six different ceiling frame styles, in steel or formed aluminum construction. Each unit is equipped with four 1-way blow cores that are easily removed and rotated to change the blow pattern. The SM series is available in square neck sizes from 6 x 6 through 24 x 24. All square sizes are available with optional round neck adapters.

## Air Distribution Products

48  
Hour



Model SSEA

### ROUND DIFFUSERS

Round ceiling diffusers are available for a variety of applications. This line includes units that are completely adjustable, semi-adjustable or non-adjustable. Adjustable units are ideal where horizontal and vertical air patterns are desired. The three position adjustable unit provides a horizontal, vertical or intermediate pattern while the non-adjustable units are for horizontal patterns.

### DIFFUSER AUXILIARY FRAME

The ASX diffuser auxiliary frame is an accessory that enables a T-bar lay-in or slot diffuser to mount to a hard ceiling. It mounts to framing above the ceiling and provides a surface to lay a T-bar diffuser into. This enables the use of a wide range of diffusers in a hard ceiling. It also creates access to the ceiling plenum to service utilities without the need to add a separate access panel. The wide flange allows for the occasional error in cutting the ceiling opening for the frame. Available in steel or extruded aluminum.

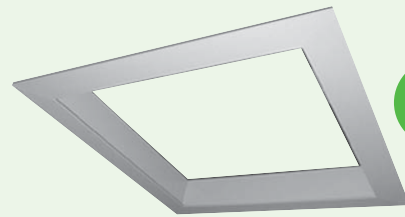

48  
Hour

Model KXFAA

EQS

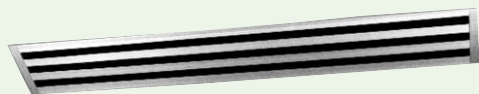

Model CHDB

### CHANNELAIRE™ DIFFUSERS

ASX Channelaire™ is an extruded aluminum linear diffuser for ceiling installation. It uses an adjustable vane in each slot to control the direction of air discharge, either parallel with or perpendicular to its surface. It is available in one to eight slots. Available slot widths are 1/2", 3/4" or 1". The unit can be provided for continuous installation from wall-to-wall or it can be provided as individual diffusers having lengths from 1 to 6 feet.

The Channelaire™ unit offers the flexibility of use as a supply or return unit as well as a blank-off section. Its design makes it adaptable for use with T-bar, spline type tile, grid type suspension or plaster ceilings. Mitered corners are available for perimeter installation.

### ARMSTRONG® TECHZONE™ COMPATIBLE LINEAR DIFFUSERS

Armstrong® TechZone™ compatible linear diffusers are specifically designed to be used with Armstrong® TechZone™ ceilings. The TechZone™ series is available for lay-in with 1-4 slots and available for tegular applications in 1-3 slots.

Slots are 3/4" and are available in the following lengths: 24", 30", 36", 48", 60" and 72".

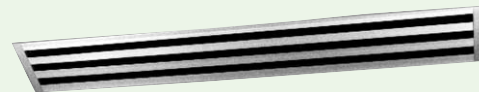

Model DTCA

EQS

*Dependance  
on quantity.  
Contact factory.*

**USG LOGIX™ COMPATIBLE  
LINEAR DIFFUSERS**

USG Logix™ compatible linear diffusers are specifically designed to be used with USG Logix™ ceilings. The Logix™ series is available for lay-in with 1-4 slots and available for tegular applications in 1-3 slots. Slots are 3/4" and are available in the following lengths: 24", 30", 36", 48", 60" and 72".

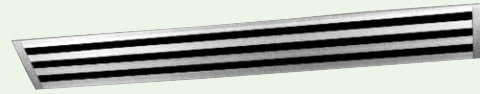

Model DTBB



*Dependance on quantity. Contact factory.*

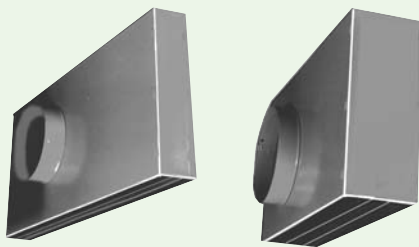

Model DASD



**ADJUSTABLE PATTERN T-BAR SLOT DIFFUSERS**

ASX DA Series adjustable pattern T-bar slot diffusers are compatible with most T-bar ceiling types. Models are also available for Donn® Finline® ceilings. They are available in 3/4", 1" or 1-1/2" wide slots in one, two, three, or four slot models. The available unit lengths are 24", 30", 36", 48" and 60". Models are available for both supply and return applications. Each supply model has an individually adjustable pattern control in each slot for horizontal or vertical air pattern. Both supply and return models are available with insulated or uninsulated plenums. The insulation conforms to UL 181 and HFPA 90A requirements. Model DAFA, which carries a UL three hour fire classification, is available in one or two slot models in 24" or 48" lengths.

**FIXED PATTERN T-BAR SLOT DIFFUSERS**

Plenum slot diffusers are an integral part of the variable air volume system. They blend in harmoniously with ceiling architecture while providing extraordinary air distribution qualities. These diffusers reduce the effect of down draft at low air quantities and discharge a remarkably uniform air flow. Plenum slot diffusers are especially valuable where there are high throttling ratios, at low CFM levels, and with cool supply air to assure proper induction and mixing with room air. They are manufactured from rust-resistant galvanized steel. Models are available for supply, return, supply with down blow feature and supply with return combination.



Model DFSB-Supply and DFRB-Return

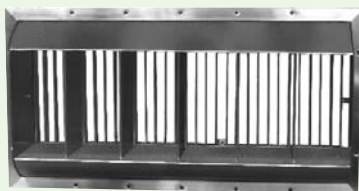

Model RAWA

**DRUM LOUVERS**

ASX drum louvers are designed to be used in applications requiring long throws with minimum duct work. The deflecting blades can be adjusted to increase or decrease air diffusion. The drum may be rotated 300 up or down from the centerline, providing a full 600 angular adjustment. The drum louvers are extruded aluminum construction and are available with or without an opposed blade balancing damper.

## Air Distribution Products

7  
Day

10  
Day

EQS



Model RSHAH

### HEAVY DUTY RETURN REGISTERS AND GRILLES

Sturdicore™ registers and grilles are specifically designed for areas where exceptional strength is required, i.e., gymnasiums, hospital psychopathic wards, etc. The 1/8" thick face bars are rounded to decrease the possibility of injury and are available in 0 and 40 degree settings. The registers are equipped with opposed blade dampers that are key-operated through the face. The heavy duty frame is reinforced at the corners for added strength. Mullions are recessed and on 6 inch centers. The grilles are all welded steel construction and come in single panel sizes up to 72 inches wide (with bars mounted horizontal) and 48 inches high.

### EGGCRATE RETURN

The all-aluminum eggcrate return grilles feature extruded aluminum frames and fabricated aluminum louvers. There are three configurations of louvers available: 1/2" x 1/2" x 1/2" deep, 1" x 1" x 1" deep and 1/2" x 1/2" x 1" deep. Registers are available with either an extruded aluminum or steel opposed blade damper.

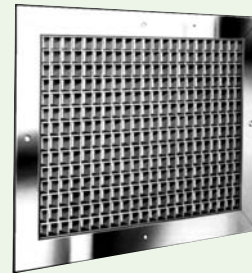

48  
Hour

EQS

Model RAPAF

48  
Hour

EQS

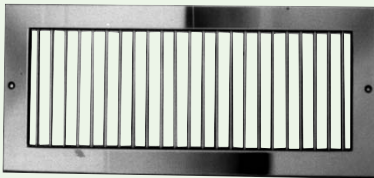

Model RSSBV

### FORMED STEEL, ALUMINUM AND STAINLESS STEEL SUPPLY AND RETURNS

Supply units are single or double deflection adjustable registers and grilles. The attractive supply units provide effective directional air stream control in one or two directions for single deflection or up to four directions for double deflection units. Return air registers and grilles are styled to match the supply units. Door and partition grilles are also available.

Formed Steel - EQS 5 & 10 Day  
Stainless Steel - EQS 10 Day

### EXTRUDED ALUMINUM SUPPLY AND RETURNS

The extruded aluminum register and grille products cover a broad line. Constructed from natural anodized aluminum extrusions, these registers and grilles are available in adjustable single and double deflection supply, or curved blade supply in 1-way, 2-way, 3-way and 4-way directional patterns. Return grilles and registers are styled to match the supply units. Extruded products have flat borders with clean sharp lines with mechanically joined corners for extra strength and minimum hairline mitered joint. Extruded aluminum door grilles are available with a channel frame, single flange frame or double flanged frame.

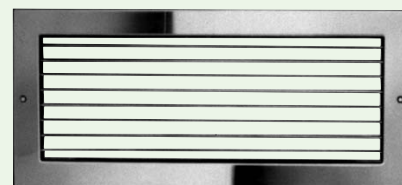

Model RASMH



### LINEAR BAR GRILLES CURTAINAIRE™ AND TRIMAIRE™

**Curtainaire™** - ASX extruded aluminum Curtainaire™ is an attractive, beautifully finished, linear type pencil proof grille. It is ideal for sill applications, efficient for high side walls and practical for use as ceiling outlets. Units are available with 3/4" or 1" borders and 0° or 15° blade deflection, sized in 2" to 24" widths in 1/2" increments and up to 72" lengths in one piece with 1/4" blades on 1/2" centers.

**Trimaire™** - ASX extruded aluminum Trimaire™ is an exquisite unit that will contribute to the appearance of any modern building interior. Available in width sizes from 2" to 24" in 1/2" increments. Trimaire™ flexibility also includes two basic surfaces--1/8" blades on 1/4" centers and 1/8" blades on 1/2" centers. Both are available in 0° and 15° deflection.

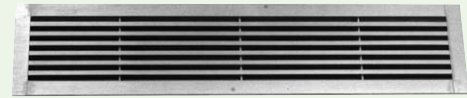

Model CCGBG

EQS

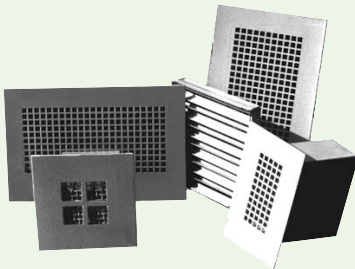

### SECURITY REGISTERS, GRILLES AND DIFFUSERS

ASX offers a complete line of security products. It consists of minimum, medium and maximum security devices. Security grilles and diffusers are available with or without volume control dampers. ASX security products meet or exceed ASTM standards. Sizes range from 4" x 4" to 48" x 48".

Many are done as specials. Contact factory for unique requirements.

### DROP BOX DIFFUSERS

The ASX drop box is designed for applications with large open spaces with high ceilings requiring a large amount of airflow and adjustability in air flow patterns. The ASX TDBA drop box can handle a range between 800 CFM and 18,300 CFM. This diffuser works very well in open ceiling plans and applications that require long throws. The TDBA is available in 4-way or 6-way blow configurations and can be ordered in sizes 14 x 14 through 42 x 42.

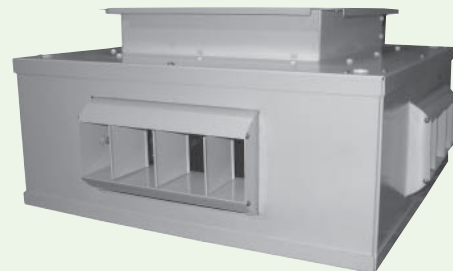

Model TDBA

## Air Distribution Products

VAV  
Quickship

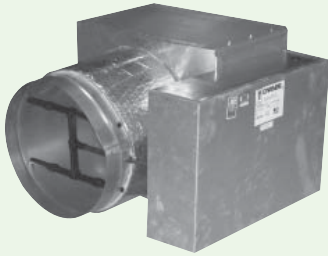

Model AV

### EXTERNALLY POWERED THROTTLING UNIT

ASX standard air terminals are designed to accurately control airflow and temperature in today's VAV systems. These units are built to provide very low pressure drops and sound levels which are certified by AHRI. All units are thermally lined with insulation meeting UL Test 181 and NFPA 90A requirements. Control options include pneumatic, electric, electronic and factory mounted digital. Optional hot water or electric reheat is available. Air capacity range from 0 to 7300 CFM.

### ROUND-TO-ROUND RETROFIT

This duct mounted retrofit unit automatically controls the air volume in high velocity air streams. The unit is installed between duct sections and will accommodate circular duct work at the inlet and discharge. The volume control unit also reduces high velocities and pressures to low velocity values. Eight unit sizes are available for duct mounting, with air capacities ranging from 0 to 4200 CFM. This design is also available with stainless steel construction.



VAV  
Quickship

Model ARR



### DDC SIMPLYVAV

ASX' SimplyVAV, by KMC, are factory supplied Direct Digital Controls (DDC) designed with you in mind. Use them in standalone or network settings. These controls are BACnet® ready, with no additional software, programming or coding required. These controllers are BLT-Listed and approved by the BACnet® community. Built-in diagnostics, or system indicators, ensure that all essential controller data is available to the operator workstation or integration engine.

### BY-PASS UNIT

ASX VAV by-pass units provide variable air volumes to individual zones while by-passing the unneeded air to the ceiling plenum for recirculation. Although zone air volumes in small buildings may vary greatly, the cost of central fan controls many times cannot be justified. Zone variable air volumes are realized with the by-pass unit while the supply fan delivers a constant CFM. Zone thermostats directly controlling the by-pass damper assures that only the air that is needed is delivered to the zones. Downstream duct work pressure losses can be matched by adjusting an integral balancing damper. Hot water reheat available.

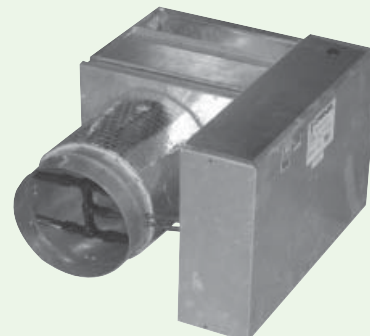

Model AB

### DUAL DUCT VAV UNIT

ASX dual duct VAV unit contains two low pressure drop throttling valves. Hot and cold duct valves are independently controlled.

Pressure independent reset constant volume controllers accurately control the hot and cold duct air flows to keep energy wasteful mixing to a minimum. Return air ducted to the hot inlet allows significant energy savings when outside air is ducted to the cold air supply. Hot and cold airstream mixing assures a constant temperature at the discharge of the unit. A wide variety of available control sequences makes the ASX dual duct VAV adaptable to most energy saving system designs. Model ADCD is used for constant volume applications. Model ADCC is used for variable volume hot and cold duct applications.

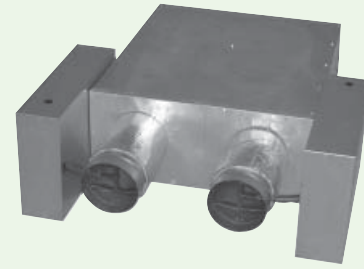

Model ADCC and ADCD

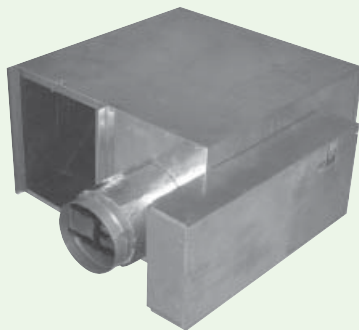

Model AC

### CONSTANT VOLUME FAN TERMINAL UNIT

The ASX constant volume fan terminal unit provides constant volume to the space while retaining the advantages of a variable air volume system. The primary air control assembly operates in the same manner as a standard throttling control valve when cooling loads are high. As cooling loads diminish, an integral blower induces warm ceiling plenum air to maintain constant volume to the zone. Optional hot water or electric reheat available. ECMotors available as a standard option.

### INTERMITTENT VOLUME FAN TERMINAL UNIT

The ASX intermittent volume fan terminal unit allows the use of recirculated air when true VAV cannot fulfill heating requirements. The intermittent fan terminal unit operates in the same manner as the throttling unit when cooling loads are high. As cooling loads diminish, an integral blower is energized and supplies recirculated air to the zone. Intermittent fan terminal units can be used to provide heat to perimeter zones with the central system fan turned off. A wide variety of control sequences makes the fan terminal unit compatible with most energy efficient system designs.

Optional hot water or electric reheat is available.

ECMotors available on most model sizes. Contact factory representative for pricing and availability.

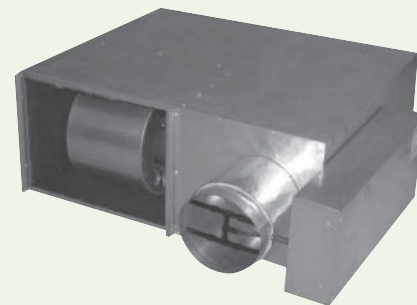

Model AS

Vent  
Express



Models VEDK/VEBK

### CENTRIFUGAL POWER ROOF VENTILATORS

ASX centrifugal power roof ventilators comprise one of the most complete lines available. The unique design of the Patented (#4890547) Diffuser Assembly (sizes 06 - 24), the innovative wheel and precision matched venturi enable the K-Series fans to reach high static pressures. Birdscreen, thermal overload (single phase motors only), conduit chase and adjustable drives are standard features on ASX ventilators. Roof ventilators are available in direct drive or belt drive arrangements. Roof curbs and backdraft dampers can be furnished as accessories. Model VEDK Direct Drive, six sizes 06-18; capacities from 70 to 4,000 CFM. Model VEBK Belt Drive, thirteen sizes 06-54; capacities from 70 to 39,000 CFM.

Units are AMCA certified for air and sound and are available with UL or CSA listings.

ECMotors are available for VEDK vents.

### CENTRIFUGAL POWER WALL VENTILATORS

ASX centrifugal power wall ventilators are available in direct drive or belt drive units and are designed to compliment the configurations of the ASX roof mounted K-Series ventilators.

The spun and shaped aluminum housing, wall mounting flange, birdscreen and safety disconnect are standard items. ASX centrifugal fan units feature backwardly inclined wheel blades with self-limiting power characteristics. The wall ventilators have the motor mounted out of the exhaust air stream, positive ventilation of the motor compartment and the motor mounting frame grounded. Model VWDK Direct Drive, sizes 06 to 18; capacities 150 to 4,000 CFM. Model VWBK Belt Drive, sizes 06-24; capacities 225 to 9,000 CFM.

Units are AMCA certified for air and sound and are available with UL or CSA listings.

Also available with UL 762 construction for kitchen applications (model VRBK).

ECMotors are available for VWDK vents.



Vent  
Express

Models VWDK/VWBK/VRBK

Vent  
Express



Models VUDK/VUBK/VRBK

### UPBLAST ROOF VENTILATORS

ASX upblast roof ventilators are offered as both belt and direct drive units. The housing is spun and shaped aluminum. Upblast units are used when it is desirable to keep the exhausted contaminants away from the roof area and avoid recirculation through the building intakes. The fan wheel is dynamically balanced and each unit is test run after assembly. Motor, bearings and drives are mounted out of the air stream insuring longer trouble-free operation. Model VUDK Direct Drive, sizes 06 to 18; capacities to 4,000 CFM. Model VUBK Belt Drive, sizes 06 to 48; capacities to 31,000 CFM.

Units are AMCA certified for air and sound and are available with UL or CSA listings.

Also available with UL 762 construction for kitchen applications (Model VRBK).

ECMotors are available for VUDK vents.

**CENTRIFUGAL UPBLAST ROOF EXHAUSTERS**

ASX VQ series centrifugal upblast fan is designed and built to handle the exhaust of extremely hot, smoke laden air during emergency fire situations. The fan discharges unbreathable air to provide vital minutes for emergency evacuations. These fans are to be roof mounted only. Model VQBL Belt Driven is available in sizes 06 through 18.

Units are AMCA certified for air and bear UL and CSA listings.



Model VQBL

**48  
Hour**

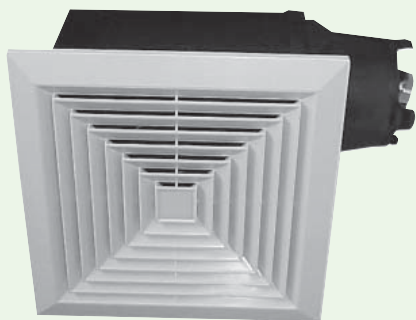

Models VCDD & VCDK

**CEILING FANS**

ASX VCDD & VCDK ceiling fans are designed to provide effective room ventilation at some of the lowest noise levels in the industry. Units are available in a standard ceiling fan configuration with an attractive plastic or metal grille, and a dedicated in-line model with two duct connections and an access panel. Units are constructed of galvanized steel, with plastic or metal blower wheels. Fourteen speed controllable sizes are available with capacities from 30 to 3500 CFM.

Units are AMCA certified for air and sound and bear UL and CSA listings.

**SQUARE IN-LINE CENTRIFUGAL FANS**

The compact in-line duct fans feature backwardly-inclined wheels and deep venturi inlet to provide superior aerodynamic performance and quiet operation. The units are available in six direct drive sizes, model VIDK 06-18 and ten belt drive sizes, model VIBK 06-36 and provide maximum air handling capacity from the minimum amount of space. Removable panels provide complete access to interior components to provide serviceability without removal from the ducts. Units can be floor mounted or hung from wall or ceiling, and mounted at any angle. Capacities range from 65 to 21,000 CFM and static pressure to 2-1/2 inches w.g.

Units are AMCA certified for air and sound and are available with UL or CSA listings.

ECMotors are available for VIDK vents.



**48  
Hour**

Models VIDK/VIBK

## Air Movement Products

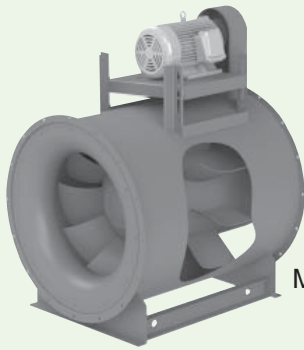

Model VMBL

### MIXED FLOW FANS

The Mixed Flow Model VMBL is available in sizes 12 through 40 and static pressure up to 5.5 inches w.g. The VMBL features bearing lubrication via extended lubrication lines and an externally adjustable base that is designed to save the user cost both in terms of energy consumption and a long trouble-free life. Shafts and bearings are sized for long and robust service life. While intended for HVAC applications, the VMBL has a heavy-duty construction, which makes it a favorite for industrial applications as well.

### UTILITY SETS - BELT DRIVE

ASX offers both forward curved and backward inclined wheel construction of utility sets. The ASX model VFB, forward curved, is available in sizes 12 through 36 with capacities to 29,000 CFM and pressures up to 5 inches w.g. The backward inclined, non-overloading model VBB is designed to perform at up to 8" w.g. static pressure. Sizes 12 to 36 are available with capacities up to 29,000 CFM.

Units are AMCA certified for air performance.



Models VFB and VBB

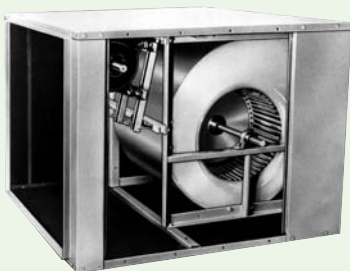

Models VDBA/VGBA

### DUCT BLOWERS

The ASX models VDBA and VGBA duct blowers are economical and efficient all purpose in-line belt driven duct blowers. These fans utilize quiet forward curve blowers which operate at low speed. The motors receive the cooling benefit of being in the airstream for increased motor life and access panels are provided for convenient servicing from two sides. Filter sections with drawer type filter racks are available as an optional accessory. Model VDBA is designed for use indoors, and model VGBA is designed with a weather proof insulated housing for both indoor and outdoor use. Thirteen sizes are available with capacities from 300 to 24,000 CFM and static pressures up to 2-1/2 inches w.g.

Units are AMCA certified for air performance.

### TUBEAXIAL FANS

The ASX tubeaxial fans are ideal for supplying or exhausting air at relatively low static pressures. These fans can be mounted from the ceiling, off the floor or within a duct. The belt driven model LIBA is available in five sizes with performance of 4,700 CFM to over 38,000 CFM at 0" static pressure. The direct drive LIDA is available in seven sizes, 12" to 36", with air performance ranging from 770 to 24,000 CFM at 0 inch static pressure.

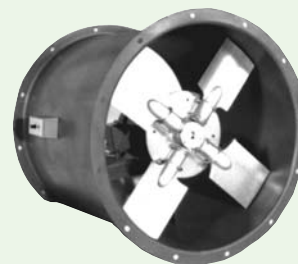

Models LIDA/LIBA

**FILTERED SUPPLY CENTRIFUGAL - BELT DRIVE**

The ASX model VNBL is a belt drive, roof mounted supply air fan designed to provide filtered, non-tempered air for a variety of applications. Available in sizes from 10" to 20" with CFM capabilities ranging from 1,000 to 13,000 and static pressures up to 1.5 inches w.g. Double width, forward curved blowers are designed to maximize efficiency. Washable aluminum filters are standard to provide long operational life. VNBL units incorporate the ASX SLIDE-RITE design. This drastically reduces the amount of fasteners required while resulting in an easy to maintain, durable, aesthetically superior design.

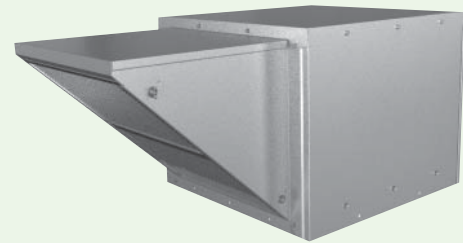

Model VNBL



Models VSBB and VHBB

**CENTRIFUGAL FILTERED SUPPLY VENTILATORS**

The ASX model VSBB filtered supply units are offered as belt driven units. The galvanized steel exterior houses 1" permanent aluminum filters and a double width forward curved blower. This roof mounted unit was designed to supply makeup air for various applications. Six sizes ranging from 08-20, deliver capacities from 500 to 13,000 CFM and static pressure up to 2 inches w.g.

The model VHBB incorporates an attractive aluminum louvered hood with mitered and welded corners.

**LOUVERED LOW SILHOUETTE CENTRIFUGAL VENTILATOR**

The model VL features an attractive low silhouette louvered ventilator that will compliment any building. This series features extruded aluminum louvers with mitered and welded corners.

Design flexibility is increased by the availability of both belt drive model VLBK sizes 06 through 54, capacities from 120 to 38,000 CFM and direct drive model VLDK sizes 06 through 18, capacities from 120 to 4,415 CFM.

Units are AMCA certified for air and sound and are available with UL or CSA listings.

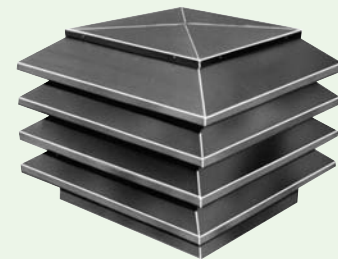

Models VLDK/VLBK

**LINEAR LOW SILHOUETTE CENTRIFUGAL VENTILATOR**

The linear appearance of the model VT provides a clean, low profile that blends attractively with modern architectural designs. The model VTBK is belt driven while the model VTDK is direct driven. Both are available with either aluminum or galvanized steel hoods. The integral curb cap and venturi is always constructed of corrosion resistant aluminum. Sizes 06 through 54 (belt drive) capacities from 120 to 38,000 CFM and 06 through 18 (direct drive) capacities from 120 to 4,415 CFM.

Units are AMCA certified for air and sound and are available with UL or CSA listings.



Models VTDK/VTBK

**LOW SILHOUETTE AXIAL ROOF VENTILATORS**

ASX line of low silhouette axial power roof ventilators are ideal for installations requiring high performance and a clean, modern appearance.

These units are available for exhaust, supply or filtered supply applications. All units are available in either belt or direct drive configuration. Capacities of the exhaust units range from 5,000 CFM to 50,000 CFM in sizes 24" to 60". Supply units, sizes 24" to 60", have capacities of 6,000 CFM to 63,000 CFM.

Filtered supply units, sizes 24" to 48", have capacities of 6,000 CFM to 45,000 CFM.



Models LTBA/LTDA, LGBA/LGDA, LFBA/LFDA

## Air Movement Products



Model LUBK

### UPBLAST PROPELLER ROOF EXHAUSTERS

Model LUBK is a high capacity roof mounted exhauster rated from 3,560 to 42,000 CFM and are available in sizes 24" through 48". It is a general ventilation unit designed to economically remove large volumes of air, fumes and vapors from commercial and industrial buildings such as warehouses, manufacturing and assembly plants, chemical plants, foundries and paper mills.

### UPBLAST AXIAL ROOF VENTILATORS

ASX model LUBA, belt drive and LUDA, direct drive upblast exhausters provide efficient discharge of contaminated air high above the roof for effective dispersion into the atmosphere. Unitized fan curb, heavy gauge windband braced against cross winds, positive closing butterfly dampers and watertight rain channels insure effective weather protection. These units are available in blade diameters of 24" through 72" with capacity to 85,000 CFM.



Models LUBA/LUDA

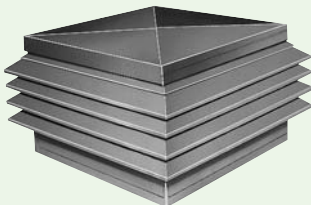

Model GL

Vent Express

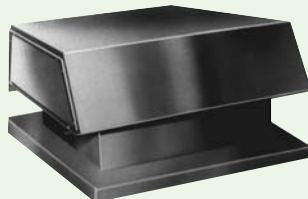

Models GE/GI

### ASX Non-Powered Ventilators

ASX offers a complete line of non-powered ventilators specifically designed to match and compliment our powered ventilators. ASX manufactures a variety of models in both aluminum and galvanized construction. Optional finishes and screens are also available.

### SERIES GL: LOUVERED INTAKE/EXHAUST

The series GL, louvered penthouse, features a low profile that blends in well with a wide variety of architectural designs. This model comes completely assembled and features aluminum construction with fully welded mitered corners. These units are available in many sizes and are suitable for either exhaust or intake applications.

### SERIES GE/GI: LOW SILHOUETTE EXHAUST/INTAKE

This attractive low silhouette design is available in both exhaust (GE) and intake (GI) models for either application. The GE model is typically used for exhaust applications. The GI models feature increased hood area that allows lower inlet velocities to reduce moisture entrainment for intake applications. These units are available in both aluminum and galvanized steel.

### SERIES GS: SPUN ALUMINUM

The GS series provides low silhouette design in an attractive spun aluminum. These units are suitable for either exhaust or intake applications. The GS features heavy gauge aluminum construction that will provide years of attractive service.

### SERIES VX: SPUN ALUMINUM ROOF CAP

ASX Series VX aluminum low silhouette roof caps offer an attractive spun design at an economical cost. These units feature a spun roof cap and an integral stamped birdscreen. VX units are available with a curb cap or a self flashing base.

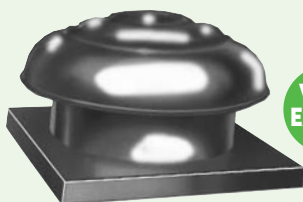

Model GS

Vent Express



Model VX

Vent Express



### Propeller Wall Fans - Belt Drive

ASX belt drive propeller wall fans provide efficient and cost effective air movement. Available in both supply and exhaust configurations, separate designs optimize cost and performance in any application.

#### **LWBK/LMBK**

This model is ideal where performance and economy are required. This version offers durable die-formed galvanized steel blades, which can deliver up to 32,000 CFM and are available in sizes 20" through 48".

Units are available with UL or CSA Listings.  
Units are AMCA Certified for Air and Sound (LW/LM only).

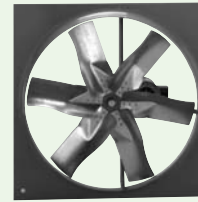

Vent Express

Model LWBK

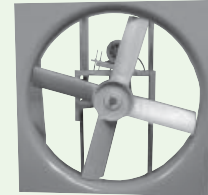

Model LRBK

#### **LRBK/LNBK**

For applications requiring greater air movement at higher static pressure and quiet operation, specify these models. Available from 24" to 72" these units utilize extruded aluminum adjustable pitch, air foil blades with capacities to over 100,000 CFM and up to 1" static pressure.

### PROPELLER WALL FANS - DIRECT DRIVE

Direct driven wall fans have the advantage of offering reduced maintenance and operating costs. These models are offered in both supply and exhaust configurations.

#### **LYDK/LZDK**

These economical fans provide premium air performance and quiet operation with aluminum blades. Sizes range from 10" to 20" with capacities up to 5,000 CFM and up to 0.75 w.g.

ECMotors are available for LYDK/LZDK vents.

#### **LJDL/LKDL**

Developed for general ventilation applications, these fans can provide advantages in first cost and low noise. They are available in five sizes 10" through 30", with capacities in excess of 12,000 CFM.

#### **LRBK/LNBK**

Models LR/LN are available in sizes 24" through 72". These units provide the advantages of direct drive, utilize adjustable pitch extruded air foil blades and offer capacities to 56,000 CFM and up to 1" w.g.

Vent Express



Model LYDK

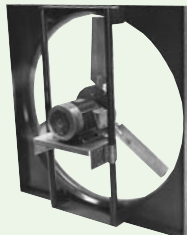

Model LRBK

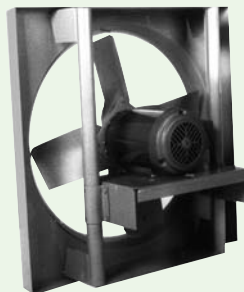

Model LJDL

Units are AMCA certified for air and sound and are available with UL or CSA listings.

## Air Movement Products



Model FPBB

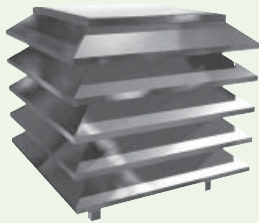

Model PMAB

Louver/  
Damper  
Fast Ship

### LOUVERS AND PENTHOUSES

ASX offers a full line of extruded aluminum and galvanized louvers and penthouses. "J" blade, drainable blade, sight proof, wind driven rain, hurricane and FEMA louvers are available in a variety of depths, in both stationary and adjustable blade designs. Anodized, baked enamel and kynar finishes are available on all louver models, in standard or custom colors to match every application. Most ASX louver models are AMCA certified for Water Penetration and Air Performance.

Penthouses are available in mitered corner, post corner and drainable blade construction, with 4" deep louver walls. Mill finish is standard. Optional anodized, baked enamel and kynar finishes are also available.

### DAMPERS

ASX offers a wide variety of gravity and motorized dampers. Counterbalanced dampers, backdraft dampers, motorized dampers, control dampers and gravity and motorized round damper models are available. Many damper models have optional corrosion resistant finishes available, and two position or modulating actuators in a wide variety of voltages.

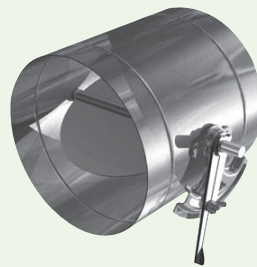

Model FAFA



Model FDCB

Louver/  
Damper  
Fast Ship

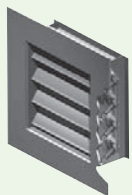

Blast  
Dampers

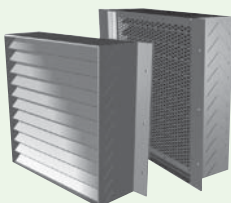

FEMA Louvers



Acoustical  
Louvers

### SPECIALTY LOUVERS AND DAMPERS

ASX now offers several specialty louver and damper products to meet all of your specific applications. ASX Blast Dampers are designed to protect buildings and structures against interior or exterior sudden blasts. FEMA Louvers protect exterior wall openings against high wind loads and wind-borne debris on FEMA compliant shelters. ASX Acoustical Louvers are available in galvanized or aluminum construction, with sound absorber of advanced microfibers.

**FIRE DAMPERS**

ASX fire dampers are UL 555 listed, ULC S112 listed and State of California Fire Marshall listed. Type A, B or C construction is available. A variety of blade designs are also available, including curtain blade, crimped (3V) blade, airfoil blade, slimline design and true round.

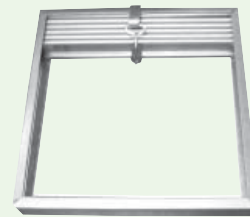

Model EABA



Model EFMA

**FIRE/SMOKE DAMPERS**

Combination fire/smoke dampers are designed to prevent the passage of both flame and smoke, to be installed at locations that are designed as both fire barriers and smoke barriers. ASX combination dampers comply with both the Standard for Fire Dampers, UL 555 and the Standard for Smoke Dampers, UL 555S.

Class I and II leakage ratings are available in a variety of blade constructions, including 3V blade, airfoil blade, true round and front (grille) access.

**SMOKE DAMPERS**

ASX smoke dampers are UL 555S listed, ULC S112.1 listed and State of California Fire Marshall listed. Smoke dampers can be used in HVAC systems where the fans shut down in the event of a fire, and can also be used in smoke control systems designed to operate during a fire.

Class I and II leakage ratings are available on all ASX smoke dampers. Blade designs include crimped (3V) blade, airfoil blade and true round.



Model ESWA



Model EDAA

**CEILING RADIATION DAMPERS**

ASX ceiling radiation dampers meet all NFPA 90A, IBC Code, and all other major code requirements for ceiling radiation dampers. Butterfly blade, fabric blade and hinged door type blade designs are available, as well as slimline designs. Thermal blanket skirts and square, rectangular or round transitions are available on most damper models.

## Air Conditioning Products

### ASX ENERGY RECOVERY

ASX, a leader in providing HVAC solutions, recognized over 50 years ago that energy conservation and equipment efficiency via Energy Recovery is the key to providing acceptable indoor air quality through outside air ventilation. A pioneer of Energy Recovery Wheels, no other manufacturer can boast a record of over 50 years of continuously providing Energy Recovery solutions to the commercial work place.

#### BENEFITS OF ENERGY RECOVERY TECHNOLOGY:

- **Energy Savings:** The energy recovery unit preconditions the outside air by exchanging heat and moisture from the outside air with the exhaust air at an efficiency that can approach 80%, saving significant energy for the building owner and allowing the outside air cooling and heating equipment can be downsized resulting in project cost reductions and rapid payback on investment.
- **Technology:** ASX Energy Recovery Wheel Units utilize an aluminum desiccant with a 3 angstrom molecular sieve for high water selectiveness, which provides effective enthalpy recovery. ASX Energy Recovery Cores provide high efficiencies in sensible only or enthalpy applications while using minimal moving parts. Both the wheel and plate units are designed to minimize airflow cross-contamination.
- **Applications:** Energy Recovery products may be used as stand-alone equipment to provide fresh air with optional supplemental heating and cooling. Or they may be attached to other air handling equipment to precondition the outside air supply to those units.
- **Certifications:** ASX Energy Recovery equipment is AHR 1060 certified for your assurance of energy recovery performance. UL listing assures electrical safety on these units. Energy exchangers meet NFPA-90A requirements.
- **ASHRAE and LEEDS:** ASX Energy Recovery equipment allows the design engineer to cost effectively meet ASHRAE Guidelines for energy and ventilation in Standards 90.1, 189.1, and 62.1. LEED Credits are available in the EA and EQ Categories.
- **Ease of Design:** Carnes ER-C-Lect Performance Software provides an easy way to select and size the various energy recovery models for the requirements of a particular project. A complete submittal is generated by the program listing features, options, performance, electrical, and dimensional information.



**Model WE Energy Recovery Ventilators** provide affordable outside ventilation by combining the ASX Energy Recovery Wheel with a make-up air handler and an exhaust fan into a compact package that minimizes capital investment and maximizes payback for heating and cooling equipment. Units available for both inside and outside mounting. Complete controls available.

Model Size	CFM Range	DIMENSIONS LISTED IN INCHES			
		Length	Width	Height	Lbs.
01	200-700	49	32	32	550
02	600-1700	58	46	38	950
03	1200-2800	70	54	49	1200
04	1550-4100	72	54	55-1/2	2000
06	2450-6500	80	72	67-1/2	2400
08	3000-8500	87-1/2	78	72-1/2	2500

#### Model WP "Core" type Energy Recovery Ventilators.

Now you can offer ERV's with Enthalpy Cores for all climates with fewer moving parts, and HRV's with sensible only cores optimized for cold climates.

WPDC with ECM Direct Drive motors for airflows 100-1,800 CFM, field configurable interior installation, controls and defrost.

WPBC Belt Drive fans for airflows 600-6,800 CFM, interior and exterior installation, double wall, controls and defrost.

DIMENSIONALS LISTED IN INCHES (Millimeters)					
Model Size	CFM Range	Length	Width	Height	Lbs.
WPDC11	100-600	46	24	35	300
WPDC12	200-1200	48	40	39	400
WPDC13	300-1800	57	56	43	500
WPBC21	600-2250	92	43	59	1150
WPBC22	1200-4500	96	63	59	1450
WPBC23	1800-6800	100	88	63	1950

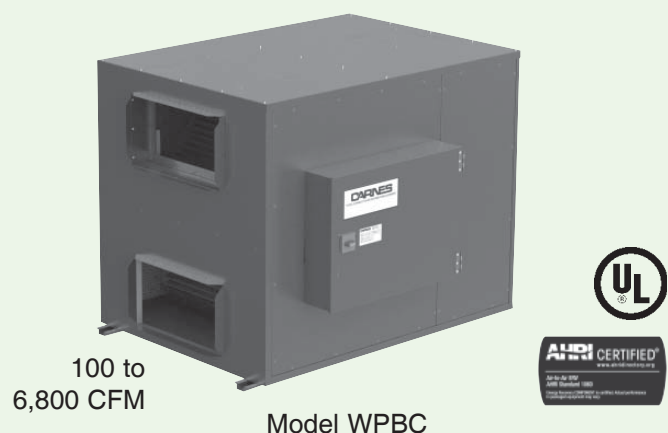



**ASX Model WM Energy Recovery Mini System** provides affordable preconditioned ventilation air, flexible design, and multiple supplemental heating/cooling options.

**BENEFITS:**

Affordable enthalpy wheel preconditioned and tempered ventilation air, with flexible and customizable design.

**FEATURES:**

- Enthalpy Wheel 3Å molecular sieve desiccant for maximum recovery and minimum cross contamination.
- Heavy duty painted steel cabinet with 1” or 2” thick double wall.
- 6 standard duct arrangements, special configurations available
- DX or chilled liquid cooling: electric, hot liquid, or gas heat.
- VFD enthalpy wheel drive and fan drives. Complete control options.

Model Size	CFM Range	DIMENSIONS LISTED IN INCHES					
		Length		Height	Width	Weight Lbs.	
		W/WA w/o Coils	Max.* w/Coils			without Coils	with Coils
WM_A03	650-2900	60	108	47-1/2	44	1300	1550
WM_A06	1740-5220	72	120	57-1/2	54	1600	1860
WM_A09	2800-7500	80	128	69-1/2	66	2100	2700
WM_A14	4300-13000	102	150	83-1/2	80	3300	4180

**ASX HUMIDIFICATION PRODUCTS**

**ASX Microprocessor Controlled Steam Humidifiers** use ordinary untreated tap water and convert it to mineral free steam for humidity control in commercial, industrial and institutional applications.

- ECONOMICAL**
- Disposable Cylinders Eliminate Periodic Maintenance for Reduced Maintenance Costs
  - Fast and Easy Installation
  - Reliable Electronic Components for Long Life
- EFFICIENT**
- Circuit Board Utilizes Microprocessor to Maximize Energy Conservation
  - Exclusive Circuit Board Design With Attached True Touchscreen Control Display
- VERSATILE**
- Digital Display Output On a True Touchscreen Control Display Providing Status and Help Buttons For Operational Details and Troubleshooting
  - Capacities up to 200 Pounds of Steam Per Hour/Unit
  - Utilize Any On-Off Humidistat, ASX Proportional Humidistat or External Signal from DDS Controls

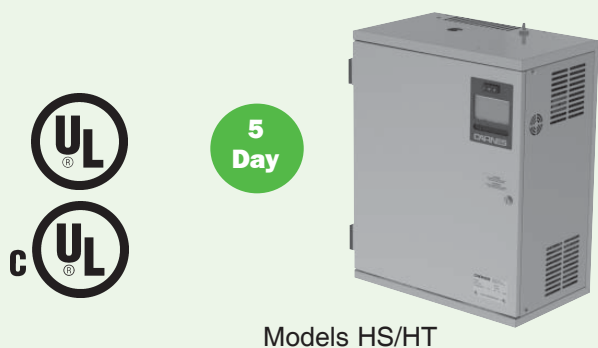

**MICROPROCESSOR CONTROLLED HUMIDIFIERS**

ASX high efficiency microprocessor controlled humidifiers are designed to solve humidification problems encountered in offices, computer rooms, health care facilities and a wide variety of manufacturing processes. The units are controlled by an advanced solid state circuit board and are completely prepped and prewired for ease of installation. ASX humidifiers generate steam from ordinary tap water using disposable plastic cylinders for low cost maintenance. A complete range of models is available with steam output rates from 5 to 200 pounds per hour.

Optional connection between ASX humidifier(s) and Building Management Systems (BMS). CarnesLink communication protocols include BACnet® (MS/TP), Modbus® (RTU), Metasys® (N2), and Siemens® (FLN).



# Quality Built Products Since 1939

---

**Vents & Fans**



**VAV Terminals**



**Registers, Grilles & Diffusers**

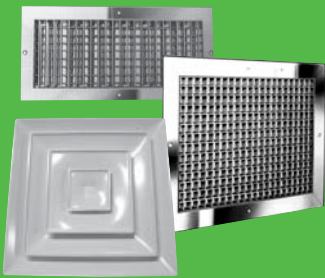

**Louvers & Penthouses**

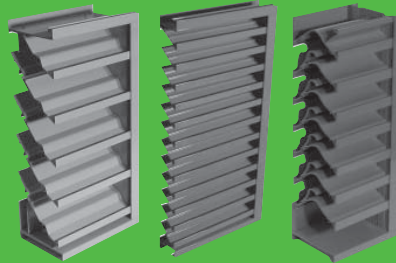

**Energy Recovery**

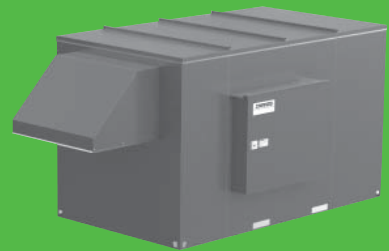

**Fire & Smoke Dampers**



**Humidifiers**



**MEMBER**



**AIR SPECIALTIES**  
**express®**

448 South Main Street  
P.O. Box 930040  
Verona, WI 53593-0040

Ph: 877/945-9175

Fax: 608/845-6504

Email: [info@airspecialties.com](mailto:info@airspecialties.com)

[WWW.AIRSPECIALTIES.COM](http://WWW.AIRSPECIALTIES.COM)