

Duct Height	Tubes
012	3
014	
016	
018	4
020	5
022	
024	6
026	7
028	
030	8
032	
034	9
036	
038	10
040	
042	11
044	
046	12
048	
048	13
	14
	15

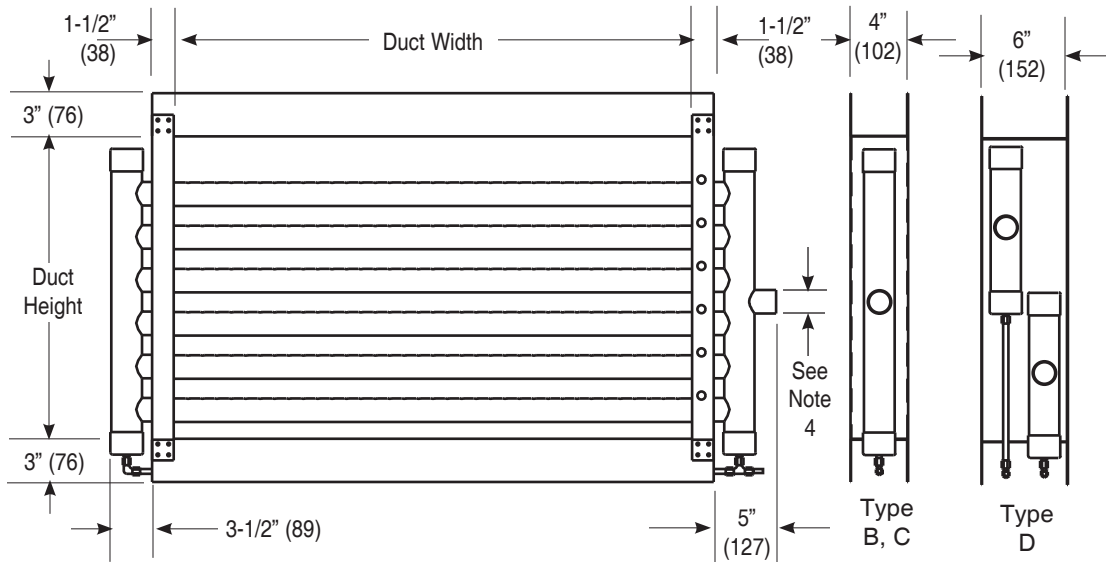

Notes:

1. Carnes short absorption manifolds are designed to provide steam with rapid absorption in the duct air stream.
2. Made of 18 guage galvanized steel frame.
3. 304 B stainless steel tubes and manifolds.
4. 3/8" copper condensate return fitting.
5. Steam connection 7/8" O.D. for Type B, 1-5/8" O.D. for Type C and D.
6. For use with Carnes "HS" and "HT" humidifiers.