

CARNES STEAM MANIFOLDS reduce the non-wetting distance when required because of space constraints in duct system.

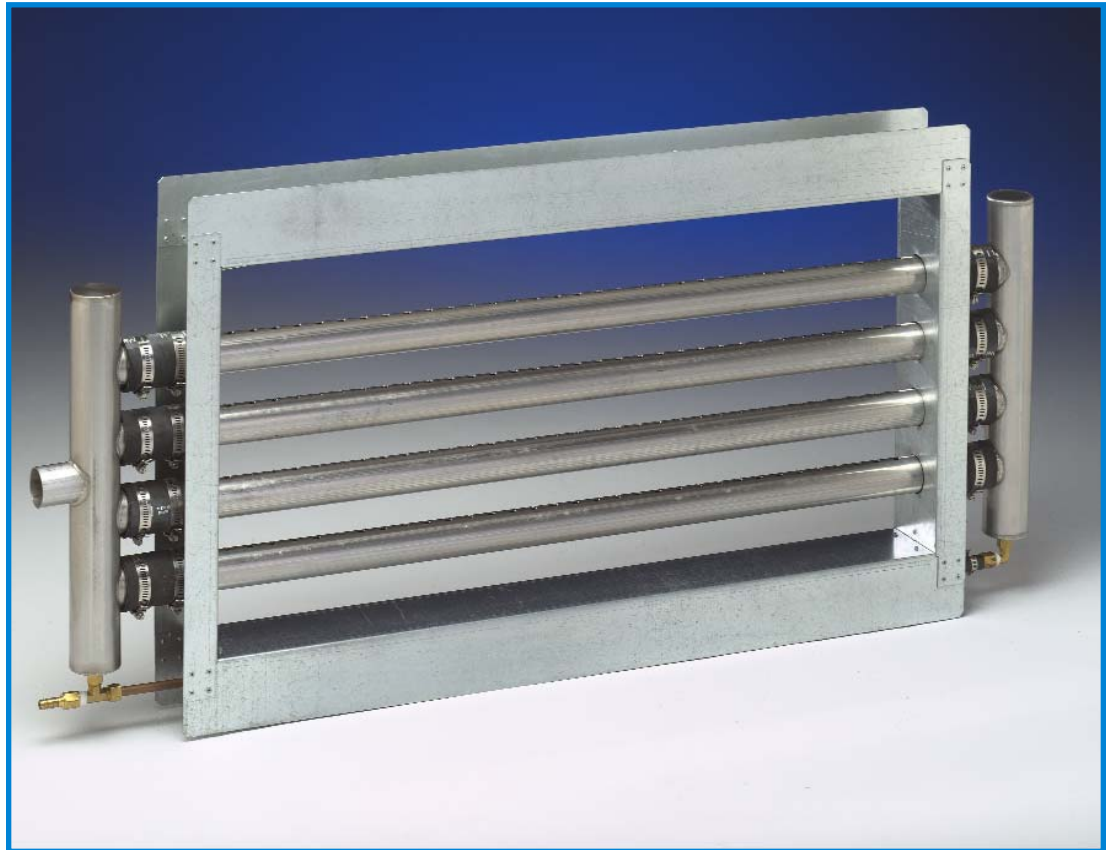

Short Absorption Manifold

Carnes Steam Manifolds are designed to provide dry steam with rapid absorption in the duct air stream. It achieves this by distributing steam evenly across the face of the duct. The distance needed for absorption is dependent on a number of factors, some of which are air velocity, steam volume, air temperature and characteristics of air flow in the duct. For minimum absorption distance, the manifold should be located in the warmest air stream of the duct and where fully developed laminar air flow occurs.

- **Stainless steel steam distribution tubes on three inch centers provide extremely short absorption distances**
- **Stainless steel manifold with flexible EPDM connections for thermal expansion without use of “O” rings**
- **Strong galvanized flanged frame for easy and fast connection to duct**
- **Factory assembled for reduced installation costs.**

**C
A
R
N
E
S**

2012

**Steam
Manifolds**

CARNES STEAM MANIFOLDS with distribution tubes on three inch centers provide extremely short absorption distances.

The following is an example of a calculation to determine the non-wetting distance of Carnes short absorption manifold. The absorption distance is based on 55°F air temperature in the supply duct. Distances will be shorter if the air temperature is higher. In this example a maximum humidifier output of 50 pounds per hour is used based on a separate load calculation that determined 44 pounds of steam were required to satisfy design conditions.

Sample Conditions

Total System Air	7,500 CFM
Incoming Outside Air	20%
Return Air	80%
Outdoor Air Design Conditions	0°F, 50% RH
Return Air (Indoor) Design Conditions	70°F, 45% RH
Supply Duct Dimensions	48" x 30"

Step 1 — Calculate Maximum Capacity of Steam Manifold:

Carnes steam manifolds can be used with steam outputs up to 25 pounds per hour of steam per square foot of duct area. If this number is exceeded water may spit from the manifold.

Formula:	Example:
25 lbs/hr/ft ²	25
x Supply Duct Area	x (48 x 30)/144
= Maximum Capacity of Steam Manifold	250 lbs/hr

In this example the 50 pounds per hour output of the humidifier is acceptable.

Step 2 — Calculate Velocity of Air in Supply Duct:

Formula:	Example:
<u>Total System Air</u>	<u>7,500 CFM</u>
Supply Duct Area	(48 x 30)/144
= Supply Air Velocity	= 750 FPM

Step 3 — Calculate Moisture Content of Air in Supply Duct Prior to Adding Steam:

Formula:	<u>Return Air Moisture Content</u>	Example:
Total System Air x % Return Air		7,500 x .80 = 6,000 CFM
Return Air x 60 minutes		6,000 x 60 = 360,000 CFH
Volume of 1 lb of Return Air (Table 1)		v = 13.50 ft³/lb
Weight of Return Air		360,000/13.50 = 26,667 lb/hr
Moisture Content of Return Air (Table 1)		w = .0070 lb/lb
Pounds of Moisture in Return Air		26,667 x .0070 = 186.7 lb/hr

Formula:	<u>Outdoor Air Moisture Content</u>	Example:
Total System Air x % Outdoor Air		7,500 x .20 = 1,500 CFM
Outdoor Air x 60 minutes		1,500 x 60 = 90,000 CFH
Volume of 1 lb of Outdoor Air (Table 2)		v = 11.62 ft³/lb
Weight of Outdoor Air		90,000/11.62 = 7,745 lb/hr
Moisture Content of Outdoor Air (Table 2)		w = .0004 lb/lb
Pounds of Moisture in Outdoor Air		7,745 x .0004 = 3.1 lb/hr

Step 4 — Calculate Relative Humidity of Air in Supply Duct Prior to Adding Steam:

Formula:	Example:
Moisture in Return Air + Moisture in Outdoor Air	186.7 + 3.1 = 189.8 lb/hr Total Moisture
Weight of Return Air + Weight of Outdoor Air	26,667 + 7,745 = 34,412 lb/hr
Humidity Ratio	189.8/34,412 = .0055 lb/lb
RH at 55°F (Table 3)	60% RH in Supply Duct

Step 5 — Calculate Relative Humidity of Air in Supply Duct After Adding Steam:

Formula:	Example:
Total Moisture + Humidifier	189.8 + 50 = 239.8 lb/hr in Supply Duct
Humidity Ratio	239.8/34,412 = .0070 lb/lb
RH at 55°F (Table 3)	76% RH in Supply Duct (interpolate between .0069 and .0074)

Step 6 — Determine Non-Wetting Distance at 55°F:

Formula:	Example:
Change in RH in Supply Duct	76% RH - 60% RH = 16% RH
Non-Wetting Distance (Table 4)	Approximately 3.9" (interpolate between 3.8 and 4.1)

CARNES STEAM MANIFOLDS are available in standard sizes from 18" x 12" through 72" x 48" in two inch increments. Additional special sizes are available.

Table 1 Return Air Conditions

°F		RH%							
		25	30	35	40	45	50	55	60
55	w	.0023	.0027	.0032	.0036	.0041	.0046	.0050	.0055
	v	13.02	13.03	13.04	13.05	13.06	13.07	13.08	13.09
60	w	.0027	.0033	.0038	.0044	.0049	.0055	.0060	.0066
	v	13.16	13.17	13.18	13.19	13.21	13.22	13.23	13.24
65	w	.0033	.0039	.0046	.0052	.0059	.0065	.0072	.0079
	v	13.30	13.31	13.33	13.34	13.35	13.37	13.38	13.40
70	w	.0039	.0046	.0054	.0062	.0070	.0078	.0086	.0094
	v	13.44	13.45	13.47	13.49	13.50	13.52	13.54	13.56
75	w	.0046	.0055	.0065	.0074	.0083	.0093	.0102	.0111
	v	13.61	13.63	13.65	13.67	13.69	13.71	13.73	13.75
80	w	.0054	.0065	.0076	.0087	.0098	.0109	.0120	.0130
	v	13.72	13.75	13.77	13.80	13.82	13.85	13.87	13.90
85	w	.0064	.0077	.0090	.0103	.0116	.0129	.0142	.0155
	v	13.87	13.90	13.93	13.96	13.99	14.02	14.05	14.08
90	w	.0075	.0090	.0105	.0121	.0136	.0152	.0167	.0183
	v	14.03	14.06	14.09	14.13	14.16	14.20	14.23	14.27

w = lb/lb
v = ft³/lb

Table 2 Outdoor Air Conditions

°F		RH%							
		20	30	40	50	60	70	80	90
0	w	.0002	.0002	.0003	.0004	.0005	.0005	.0006	.0007
	v	11.62	11.62	11.62	11.62	11.62	11.63	11.63	11.63
5	w	.0002	.0003	.0004	.0005	.0006	.0007	.0008	.0009
	v	11.75	11.75	11.75	11.75	11.75	11.76	11.76	11.76
10	w	.0003	.0004	.0005	.0007	.0008	.0009	.0010	.0012
	v	11.87	11.88	11.88	11.88	11.88	11.89	11.89	11.89
15	w	.0003	.0005	.0007	.0008	.0010	.0012	.0013	.0015
	v	12.00	12.00	12.01	12.01	12.01	12.02	12.02	12.02
20	w	.0004	.0006	.0009	.0011	.0013	.0015	.0017	.0019
	v	12.13	12.13	12.14	12.14	12.15	12.15	12.15	12.16
25	w	.0005	.0008	.0011	.0014	.0016	.0019	.0022	.0025
	v	12.26	12.26	12.27	12.27	12.28	12.28	12.29	12.29
30	w	.0007	.0010	.0014	.0017	.0021	.0024	.0028	.0031
	v	12.39	12.39	12.40	12.41	12.41	12.42	12.43	12.44
35	w	.0008	.0013	.0017	.0021	.0026	.0030	.0034	.0038
	v	12.52	12.53	12.53	12.54	12.55	12.56	12.57	12.58

w = lb/lb
v = ft³/lb

Table 3
Relative Humidity at 55°F

w	RH%
.0005	5
.0009	10
.0014	15
.0018	20
.0023	25
.0027	30
.0032	35
.0037	40
.0041	45
.0046	50
.0050	55
.0055	60
.0060	65
.0064	70
.0069	75
.0074	80
.0078	85
.0083	90
.0087	95

Table 4
Non-Wetting Distance at 55°F

Change in RH%	500 fpm	750 fpm
5	4.2"	3.3"
10	4.5"	3.5"
15	4.9"	3.8"
20	5.3"	4.1"
25	5.7"	4.3"
30	6.2"	4.7"
35	6.7"	5.0"
40	7.3"	5.4"
45	7.7"	5.8"
50	8.6"	6.3"
55	9.4"	6.8"
60	10.2"	7.4"
65	11.2"	8.0"
70	12.2"	8.7"
75	13.3"	9.5"
80	14.6"	10.3"
85	16.0"	11.3"
90	17.5"	12.3"
95	19.1"	13.4"

Table 5
Air Pressure Loss, " wg

500 fpm	.02
750 fpm	.07

Table 6 Model Numbering System

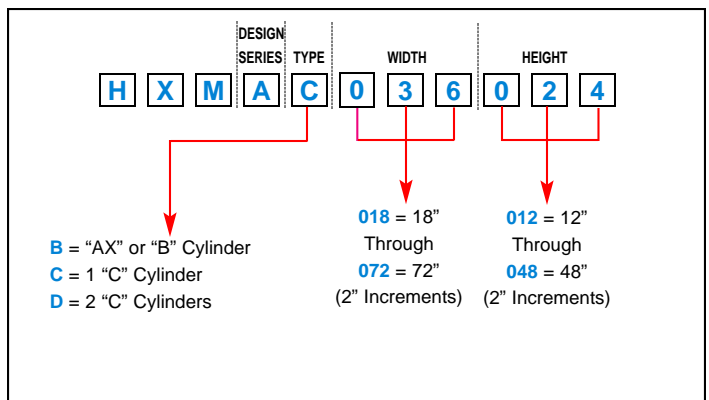

Dimensions

Table 7

Duct Height	Tubes
012	3
014	4
016	5
018	6
020	7
022	8
024	9
026	10
028	11
030	12
032	13
034	14
036	15
038	
040	
042	
044	
046	
048	

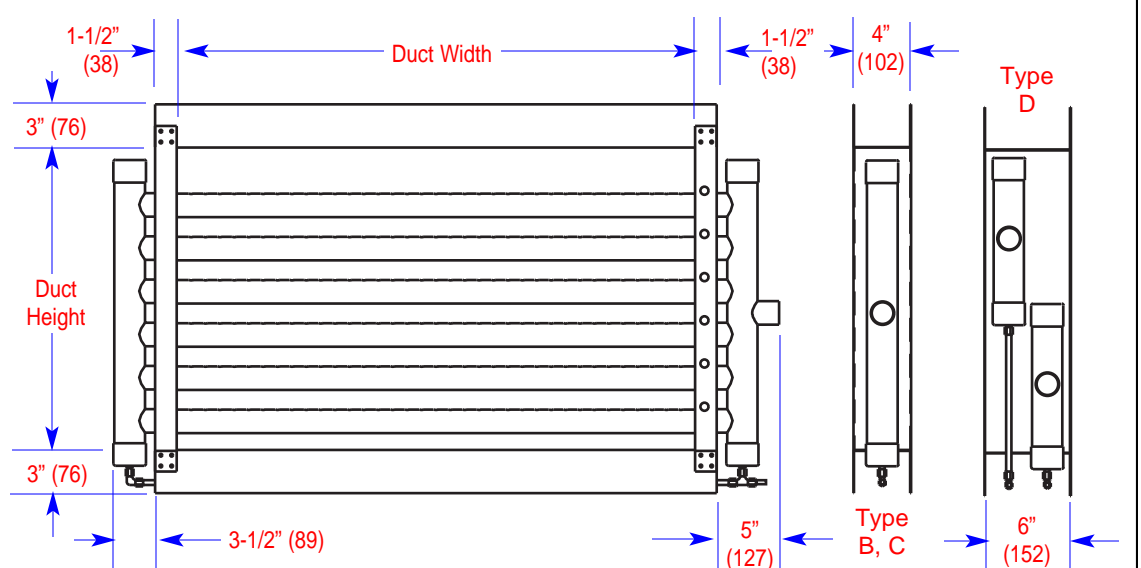

CARNES STEAM MANIFOLDS with strong galvanized flanged frames are factory assembled to reduce installation costs.

LOCATION OF MANIFOLD

The manifold is usually located in the supply duct downstream of the fan, heating coil, cooling coil, and/or filter. When installed in packaged units, the manifold is to be mounted just downstream of the fan discharge.

The non-wetting dimension is the distance necessary to prevent condensation on any obstruction downstream from the manifold. Condensation could occur on a cooling coil because of lower temperatures. Steam plumes may be visible beyond the non-wetting dimension and may moisten high efficiency filters. Additional distance is required for installation upstream of high efficiency filters.

Carnes humidifiers operate at .5 psi or less so there are limitation on the length between the humidifier cabinet and the steam manifold. The maximum distance depends on the static pressure in the duct and is shown in [Table 8](#).

Table 8 Maximum Steam Hose Length

Duct Static Pressure "wg	0	1	2	3	4	5
Maximum Steam Hose Length (Ft.)	40	35	30	25	15	10

In a typical installation, the humidifier is located below the duct and the steam manifold is installed as shown in [Figure A](#). The maximum recommended length of steam hose for this type of installation is 12 feet.

For lengths beyond 12 feet additional steps are shown in [Figure B](#). If sufficient headroom is not available, it is possible to install the steam hose with an upward slope with a minimum rise of 2" for every 12" of run.

The steam manifold may be located below the humidifier if the installation is made in accordance with [Figure C](#). The steam manifold cannot be installed in a vertical duct.

The manifold has an integral mounting flange for ease of installation. Separate mounting flanges, supplied by others, are needed to mate with the manifold. Refer to [Figure D](#).

If the steam manifold is used with a humidifier having two cylinders it will require two separate lengths of steam hose. **Do not combine the outputs of two cylinders into one steam hose.**

It is very important that both the steam hose and condensate return line be installed so that sags are prevented.

If it is difficult to prevent sags, it is recommended that copper tube be used as a substitute. If copper tube is used, a minimum of one inch of insulation must be applied to prevent excessive condensation and contact with the hot pipe. A short length of steam hose must be used to connect the plastic cylinder in the humidifier to the copper tube and another to connect the copper tube to the steam manifold.

Size 3/4" copper tube can be used with steam cylinders having output rates up to 30 pounds per hour. Size 1-1/2" copper tube should be used with steam cylinders over 30 pounds per hour. Length restrictions shown in [Table 8](#) also apply where copper tube is used and any 90° elbows add approximately three feet of equivalent length.

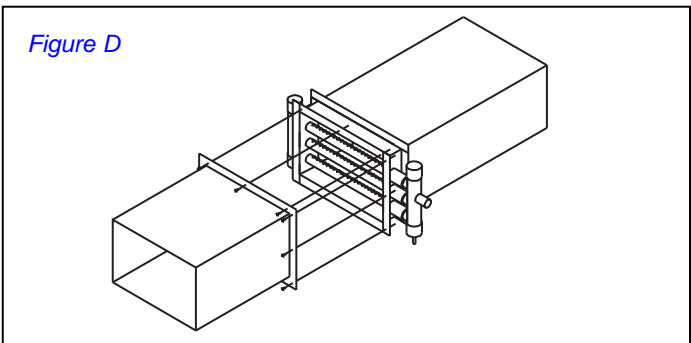
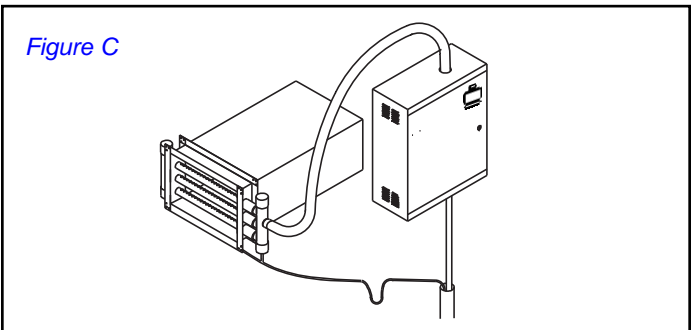
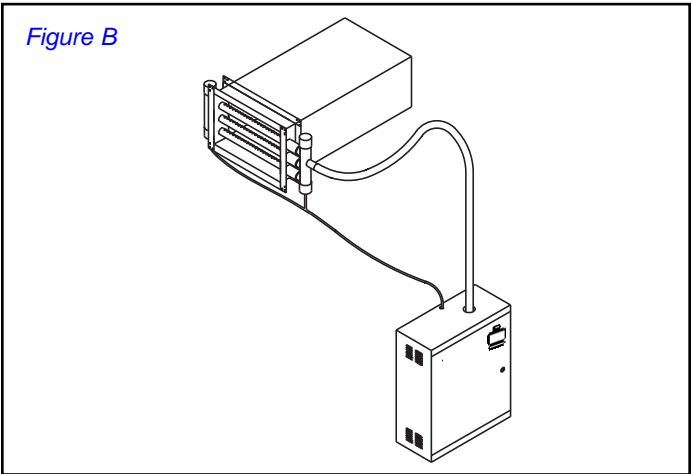
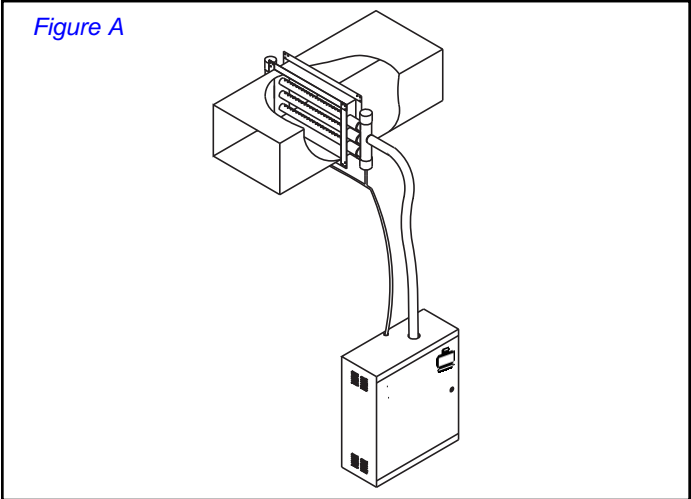

Contact us at: Carnes Company, 448 South Main Street, Verona, WI 53593-0040
 Phone: 608.845.6411 • Fax: 608.845.6504 • Email: carnes@carnes.com • Web: www.carnes.com