

CARNES COMPANY, 448 S. Main St., P. O. Box 930040, Verona, WI 53593-0040 Phone: (608)845-6411 Fax: (608)845-6504 carnes@carnes.com

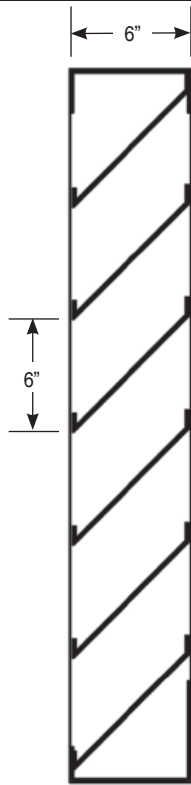

Section View

Model FVCB

Standard Specifications

Frame: 18 gauge galvanized steel, 6" deep

Blades: drainable, 20 gauge galvanized steel, positioned at 45° angles on approximately 5.875" centers

Finish: mill galvanized

Screen: 1/2" x .050" expanded flattened aluminum in removable frame. Screen is mounted on inside (rear) as looking from exterior of building.

Maximum Panel Size: 72"w x 96"h

Larger sizes made in multiple sections

Minimum Panel Size: 8"w x 12"h

Options (at additional cost)

- 304 Stainless Steel Construction
- Filter Racks
- Security Bars
- Variety of Screens
- Sub-Frames
- Selection of finishes; prime coat, kynar, baked enamel, epoxy and heresite

Consult Carnes for other special requirements.

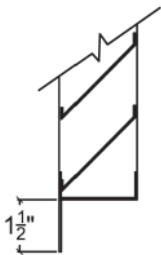

Flanged Frame
Optional

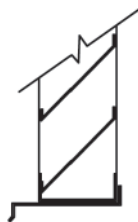

Extended Sill
Optional

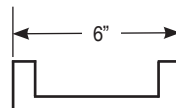

Typical
Jamb

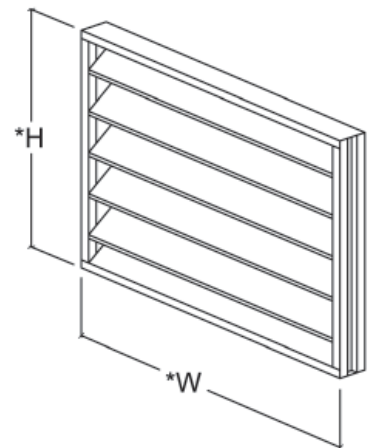

*Width and height dimensions are approximately 1/4" under listed size.

Tag	Qty.	Size		Frame	Variations
		Width	Height		

Project
Arch./Engr.
Representative

Location
Contractor
Date