

CARNES COMPANY, 448 S. Main St., P. O. Box 930040, Verona, WI 53593-0040 Phone: (608)845-6411 Fax: (608)845-6470 carnes@carnes.com

Model FAEA is an ideal manual balancing damper for duct up to 36" x 12".

Standard Construction

Frame: .081" aluminum, 4-1/2" deep

Blades: .125" aluminum

Bearing: nylon 6/6

Hand Quadrant: 1/2" cast zinc

Maximum Velocity: 2000 fpm

Variations

- 2" Stand Off Quadrant
- All Stainless Steel including Quadrant

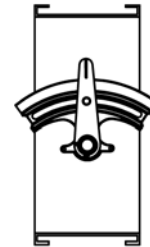
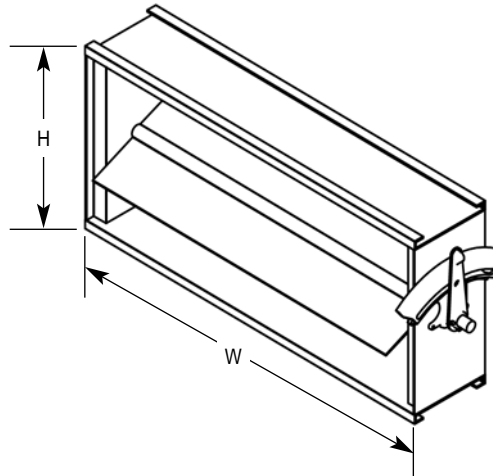

Undersized
approx. 1/4"

Tag	Qty.	Size		Frame	Variations
		Width	Height		

Project
Arch./Engr.
Representative

Location
Contractor
Date