

Imperial [IP] Dimensions  
Metric (SI) in Parentheses

CARNES COMPANY 448 S. Main St., P. O. Box 930040, Verona, WI 53593-0040 Phone: (608)845-6411 Fax: (608)845-6504 www.carnes.com

**Standard Construction:**

- 20" and under = 18 gauge Galvanized Steel
- 20-1/2" through 30-1/2" = 16 gauge Galvanized Steel
- Above 30-1/2" = 14 gauge Galvanized Steel

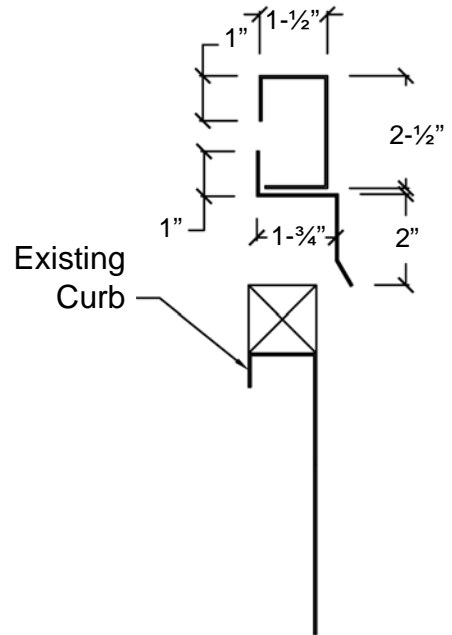
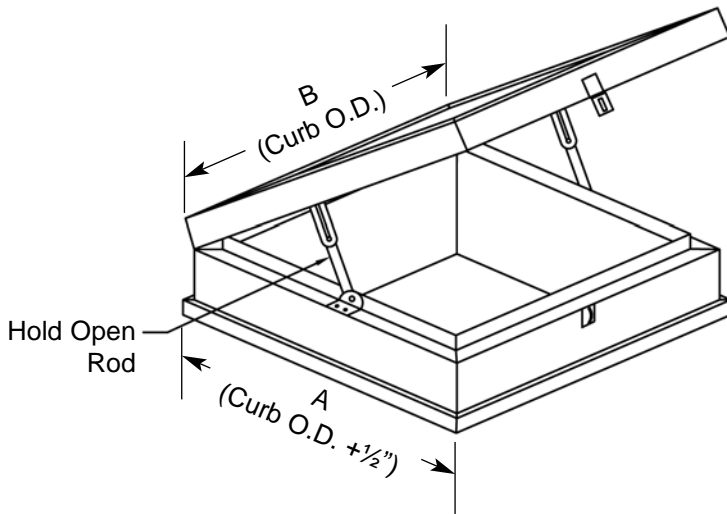

**SECTION VIEW**

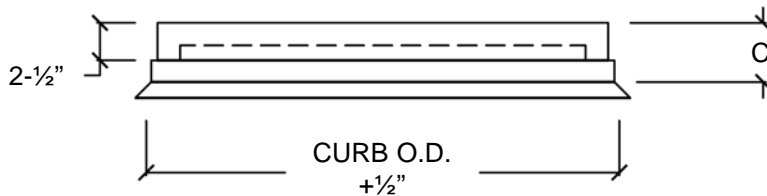

Tag	Qty.	A	B	C	Fan Model